

# 750

## Hydraulic Swing Gate Operator

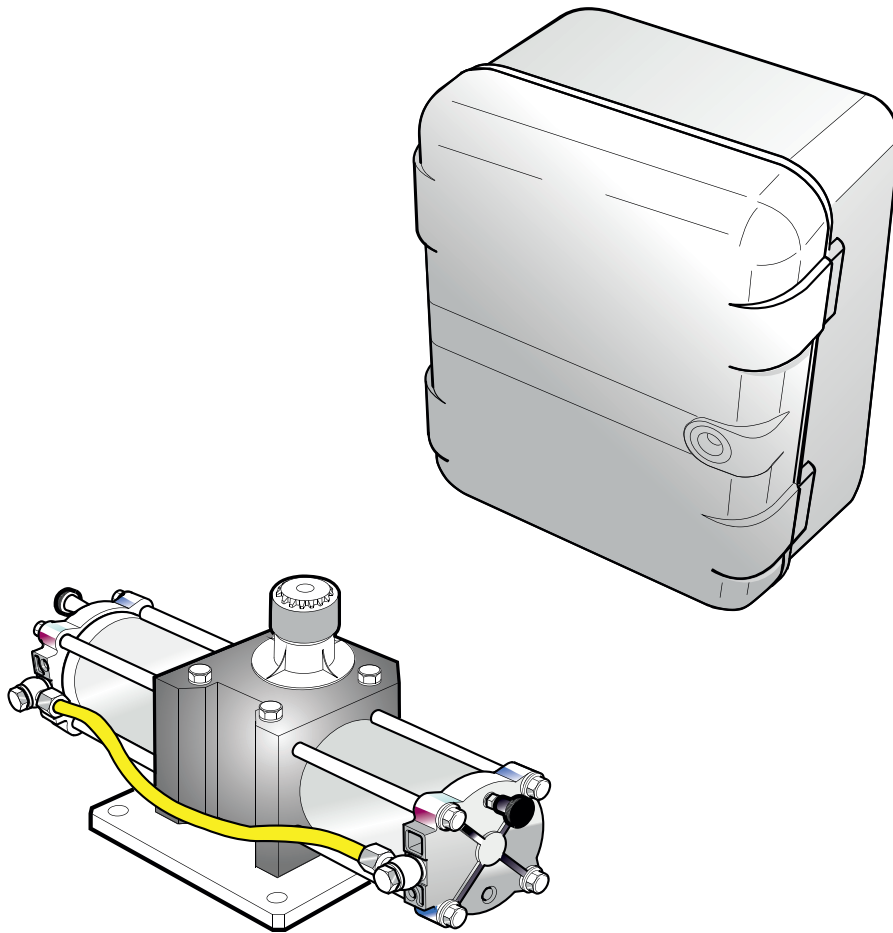

FAAC International Inc.  
Headquarter & East Coast Operations  
3160 Murrell Rd  
Rockledge, FL 32955  
Tel. 800 221 8278

FAAC International Inc.  
West Coast Operations  
17595 Cartwright Rd  
Irvine, CA 92614

# FAAC

**TABLE OF CONTENTS**

Important Safety Information	3		
Important Installation Information	3		
General Safety Precautions	4		
UL325 Gate Operator Classifications	5		
Installing the Warning Signs	5		
<b>750 OPERATOR</b>			
<b>1. DESCRIPTION TECHNICAL SPECIFICATIONS</b>	<b>6</b>		
<b>2. INSTALLATION</b>	<b>7</b>		
2.1. Preliminary Checks	7		
2.2. Installing the Drive Unit	7		
2.3. Installing the Hydraulic Control Unit	8		
2.4. Hydraulic Connection	9		
2.5. Air Bleed Operations	10		
2.5. Installing The Gate	11		
<b>3. FINAL OPERATIONS</b>	<b>12</b>		
3.1. Adjusting the By-Pass Valves	12		
<b>4. MANUAL OPERATION</b>	<b>12</b>		
<b>5. MAINTENANCE</b>	<b>12</b>		
		<b>455D CONTROL BOARD</b>	
		1. General Description	14
		2. Technical Specifications	14
		3. Features	14
		4. Layout and Components	14
		5. Electric Connections	15
		6. Connection of Safety Devices	16
		7. Operating Logics	18
		8. Programming	18
		9. Start-up	20
		10. Learning Operating Times	21
		11. Final Tests	21
		12. Operating Modes Detailed Description	22
		13. Prewired Enclosure	24
		<b>SPARE PARTS</b>	
		Hydraulic Drive Unit	28
		Hydraulic Control Unit	29

## IMPORTANT SAFETY INFORMATION

WARNING - to reduce the risk of severe injury or death:

1. READ AND FOLLOW ALL INSTRUCTIONS.
2. Never let children operate or play with the gate controls. Keep remote controls away from children.
3. Always keep people and objects away from the gate. NO ONE SHOULD CROSS THE PATH OF A MOVING GATE.
4. Test the gate operator monthly. The gate MUST reverse on contact with a rigid object or stop when an object activates the non-contact sensors. After adjusting the force or the limit of travel, retest the gate operator. Failure to adjust and retest the gate operator properly can increase the risk of severe injury or death.
5. Use the manual release only when the gate is not moving.
6. KEEP GATES PROPERLY MAINTAINED. Read the user's manual. Have a qualified service person make repairs to gate hardware.
7. The entrance is for vehicles only. Pedestrians must use a separate entrance.
8. SAVE THESE INSTRUCTIONS.

## IMPORTANT INSTALLATION INFORMATION

- a) Install the gate operator only when:
  - 1) The operator is appropriate for the construction of the gate and usage Class of the gate,
  - 2) All openings of a horizontal slide gate are guarded or screened from the bottom of the gate to a minimum of 1.83 m (6 ft) above the ground to prevent a 57.2 mm (2-1/4 in) diameter sphere from passing through openings anywhere in the gate, and in that portion of the adjacent fence that the gate covers in the open position,
  - 3) All areas of the moving vertical pivot gate panel from the bottom of the gate to the top of the gate or a minimum of 1.83 m (72 in) above grade, whichever is less, that pass by a fixed stationary object, and in the area of the adjacent fence that the gate covers during the travel of the gate, shall be designed, guarded or screened to prevent a 57.2 mm (2-1/4 in) diameter sphere from passing through such areas.
  - 4) All exposed pinch points are eliminated or guarded, and
    - 5) Guarding is supplied for exposed rollers.
    - 6) The operator instructions shall list the maximum number of open and close entrapment protection devices capable of being connected to the operator.
- b) The operator is intended for installation only on gates used for vehicles. Pedestrians must be supplied with a separate access opening. The pedestrian access opening shall be designed to promote pedestrian usage. Locate the gate such that persons will not come in contact with the vehicular gate during the entire path of travel of the vehicular gate.
- c) The gate must be installed in a location so that enough clearance is supplied between the gate and adjacent structures when opening and closing to reduce the risk of entrapment. Swinging gates shall not open into public access areas.
- d) The gate must be properly installed and work freely in both directions prior to the installation of the gate operator. Do not over-tighten the operator clutch or pressure relief valve to compensate for an improperly installed, improperly functioning, or damaged gate.
- e) For gate operators utilizing Type D protection:
  - 1) The gate operator controls must be placed so that the user has full view of the gate area when the gate is moving,
  - 2) An additional placard that is marked in letters at least 6.4-mm (1/4-in) high with the word "WARNING" and the following statement or the equivalent: "Moving Gate Has the Potential of Inflicting Injury or Death – Do Not Start Gate Unless Path is Clear." shall be placed adjacent to the controls,
  - 3) An automatic closing device (such as a timer, loop sensor, or similar device) shall not be employed, and
  - 4) No other activation device shall be connected.
- f) Permanently mounted controls intended for user activation must be located at least 1.83 m (6 ft) away from any moving part of the gate and where the user is prevented from reaching over, under, around or through the gate to operate the controls.
 

*Exception: Emergency access controls only accessible by authorized personnel (e.g. fire, police, EMS) may be placed at any location in the line-of-sight of the gate.*
- g) The Stop and/or Reset buttons must be located within line-of-sight of the gate. Activation of the reset control shall not cause the operator to start.
- h) A minimum of two (2) WARNING SIGNS shall be installed, in the area of the gate. Each placard is to be visible by persons located on the side of the gate on which the placard is installed.
- i) For gate operators that utilize a non-contact sensor (photo beam or similar):
  - 1) See instructions on the placement of non-contact sensors for each type of application,
  - 2) Care should be exercised to reduce the risk of nuisance tripping, such as when a vehicle trips the sensor while the gate is still moving, and
  - 3) One or more non-contact sensors shall be located where the risk of entrapment or obstruction exists, such as the perimeter reachable by a moving gate or barrier.

- j) For gate operators that utilize a contact sensor (edge sensor or similar):
- 1) One or more contact sensors shall be located where the risk of entrapment or obstruction exists, such as at the leading edge, trailing edge, and postmounted both inside and outside of a vehicular horizontal slide gate.
  - 2) One or more contact sensors shall be located at the bottom edge of a vehicular vertical lift gate.
  - 3) One or more contact sensors shall be located at the pinch point of a vehicular vertical pivot gate.
  - 4) A hardwired contact sensor shall be located and its wiring arranged so that the communication between the sensor and the gate operator is not subjected to mechanical damage.
  - 5) A wireless device such as one that transmits radio frequency (RF) signals to the gate operator for entrapment protection functions shall be located where the transmission of the signals are not obstructed or impeded by building structures, natural landscaping or similar obstruction. A wireless device shall function under the intended end-use conditions.
  - 6) One or more contact sensors shall be located on the inside and outside leading edge of a swing gate. Additionally, if the bottom edge of a swing gate is greater than 152 mm (6 in) but less than 406 mm (16 in) above the ground at any point in its arc of travel, one or more contact sensors shall be located on the bottom edge.
  - 7) One or more contact sensors shall be located at the bottom edge of a vertical barrier (arm).

## GENERAL SAFETY PRECAUTIONS

### Gate Construction

Vehicular gates should be constructed and installed in accordance with ASTM F2200: Standard Specification for Automated Vehicular Gate Construction.

For a copy of the standard, contact ASTM directly at 610-832-9585 or [www.astm.org](http://www.astm.org)

### Installation

- If you have any questions or concerns regarding the safety of the gate operating system, do not install the operator and consult the manufacturer.
- The condition of the gate structure itself directly affects the reliability and safety of the gate operator.
- Only qualified personnel should install this equipment. Failure to meet this requirement could cause severe injury and/or death.
- The installer must provide a main power switch that meets all applicable safety regulations.
- It is extremely unsafe to compensate for a damaged gate by increasing the operator's force.
- Install devices such as reversing edges and photo beams to provide better protection for personal property and pedestrians. Install reversing devices that are appropriate to the gate design and application.
- Before applying electrical power, ensure that voltage requirements of the equipment correspond to the supply voltage. Refer to the label on your gate operator system.

### Usage

- Use this equipment only in the capacity for which it was designed. Any use other than that stated should be considered improper and therefore dangerous.
- The manufacturer cannot be held responsible for damage caused by improper, erroneous or unreasonable use.
- If a gate system component malfunctions, disconnect the main power before attempting to repair it.
- Do not impede the movement of the gate, you may injure yourself or damage the gate system as a result.
- This equipment may reach high thermal temperatures during normal operation, therefore use caution when touching the external housing of the gate operator.
- Use the manual release mechanism according to the procedures presented in this manual.
- Before performing any cleaning or maintenance operations, disconnect power to the equipment.
- All cleaning, maintenance or repair work must be performed by qualified personnel.

## UL325 Gate Operator Classifications

---

### CLASS I - RESIDENTIAL VEHICULAR GATE OPERATOR

A vehicular gate operator (or system) intended for use in garages or parking areas associated with a residence of one to four single families.

---

### CLASS II - COMMERCIAL / GENERAL ACCESS VEHICULAR GATE OPERATOR

A vehicular gate operator (or system) intended for use in commercial locations or buildings such as multi-family housing units (five or more single family units), hotel, garages, retail store, or other buildings accessible by or servicing the general public.

---

### CLASS III - INDUSTRIAL / LIMITED ACCESS VEHICULAR GATE OPERATOR

A vehicular gate operator (or system) intended for use in an industrial location or building such as a factory or loading dock area or other locations not accessible by or intended to service the general public.

---

### CLASS IV - RESTRICTED ACCESS VEHICULAR GATE OPERATOR

A vehicular gate operator (or system) intended for use in guarded industrial locations or buildings such as an airport security area or other restricted access locations not servicing the general public, in which unauthorized access is prevented via supervision by security personnel.

---

## Installing the Warning Signs

---

This FAAC swing gate operator is supplied with two warning signs to alert people that a possible hazard exists and that appropriate actions should be taken to avoid the hazard or to reduce exposure to it.

Permanently install one warning sign on each side of the gate so they are fully visible to traffic and pedestrians.

Use appropriate hardware such as metal screws (not supplied) to permanently install each warning sign.



# 750 OPERATOR

The 750 is an automatic gate operator for a swinging gate leaf. It makes possible to automate gates in a virtually invisible way.

The operator is a two piece unit consisting of a hydraulic control unit (pump) and a hydraulic drive unit which are connected by the means of two hydraulic hoses.

The 750 Operator also includes a key operated Manual Release mechanism and two bypass valves that precisely control the force applied to the gate leaf through the operator.

**The 750 operator is designed and built to automate vehicular swing leaf gates. Do not use for any other purpose.**

## 1 DESCRIPTION AND TECHNICAL SPECIFICATIONS

**Tab.1 - Technical Specifications for hydraulic control unit**

<b>Input voltage</b>	115Vac (+10% -6%) or 230Vac (+6% -10%)
<b>Power</b>	220W
<b>Current</b>	2A (115V) - 1A (230V)
<b>Electric motor speed</b>	1400 rpm
<b>Thrust capacitor</b>	25 uF (115V) - 8uF (230V)
<b>Thermal protection</b>	248°F (120°C)
<b>Use frequency (cycles/h) (1)</b>	45 cycles/hour
<b>Oil quantity</b>	1.05 Qt (1 l)
<b>Oil type</b>	FAAC HP OIL
<b>Operating ambient temperature</b>	4°F + 131°F (-20 °C +55°C)
<b>Protection class</b>	IP 55
<b>Weight</b>	16.5 lb (7.5Kg)
<b>Pump capacity</b>	0,75 (l/min)
<b>Max leaf length</b>	13 ft (4 m)
<b>Min leaf length</b>	8 ft (2.4 m)

(1) Exposure to direct sunlight can determine a drop in use frequency.

**Tab.2 - Technical specifications for hydraulic drive unit**

MODELS	100°	180°
<b>Max leaf weight</b>	1760 lb (800Kg)	
<b>Max rotation angle</b>	118°	200°
<b>Max torque</b>	400 lbf (543Nm)	
<b>Angular speed</b>	7.8° / sec	
<b>Oil quantity</b>	0.31 Qt (0.3 l)	0.53 Qt (0.5 l)
<b>Protection class</b>	IP 67	
<b>Weight</b>	17.6 lb (8Kg)	19.8 lb (9Kg)

Always separate low voltage wiring from AC power cables. Use separate conduits to avoid electrical interference.

The installer is responsible for grounding the gate and operator systems, for providing the main power breaker switch, and for making sure that the entire gate system meets all applicable electrical codes.

Make sure to locate all controls that operate the gate system at least 6 ft away from any moving parts.

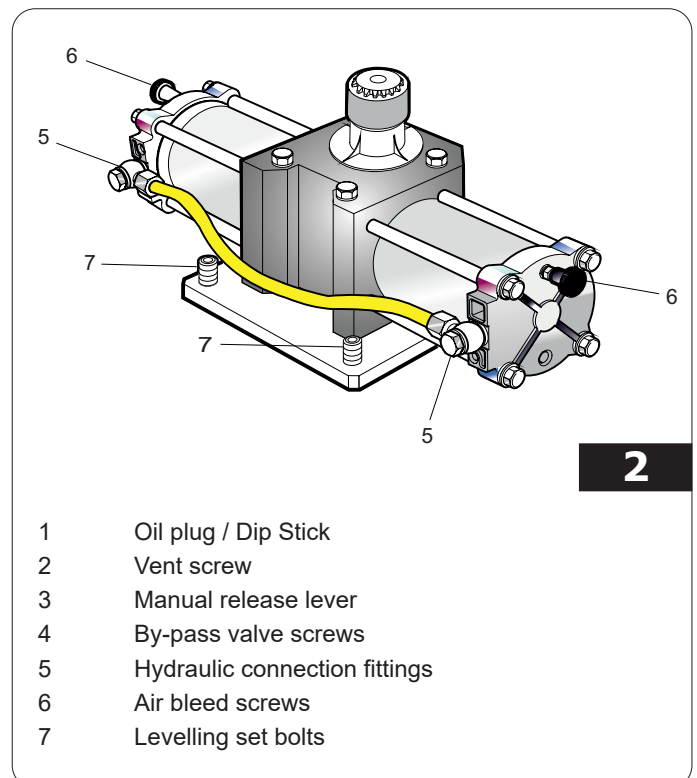
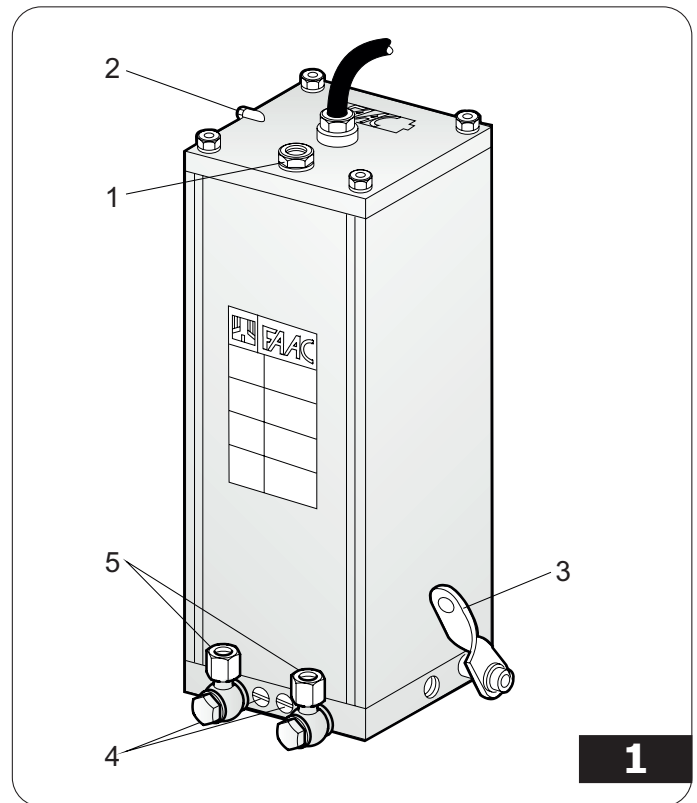

2 INSTALLATION

2.1 PRELIMINARY CHECKS

Before you install the 750 Operator, you must insure that the gate leaf meets the following criteria.:

- weight of each leaf no more than 1760 lb (800 kg);
- maximum length of each leaf must be 13 ft (4 m) (see tab.1);
- sturdy and rigid leaf structure;
- smooth and even movement of the leaves, without irregular friction during the entire swing;
- The gate must swing level
- good condition of the existing hinges;
- presence of mechanical limit stops.

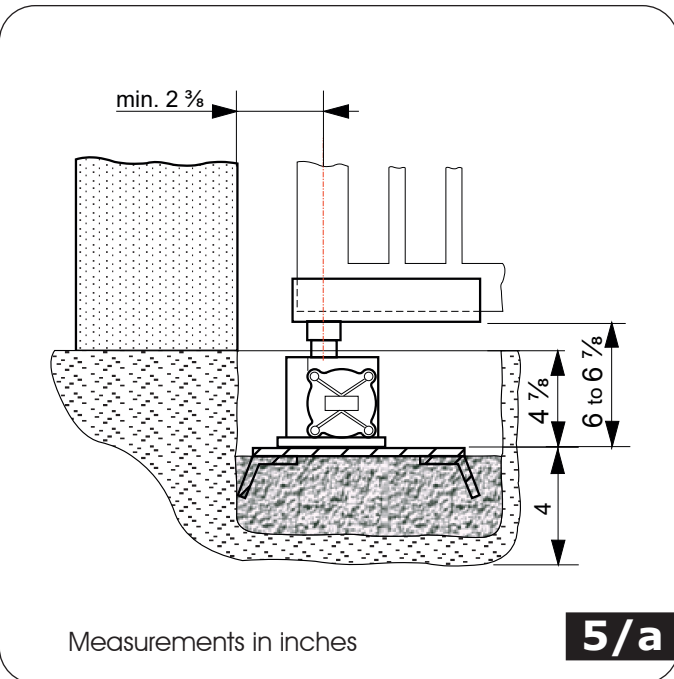
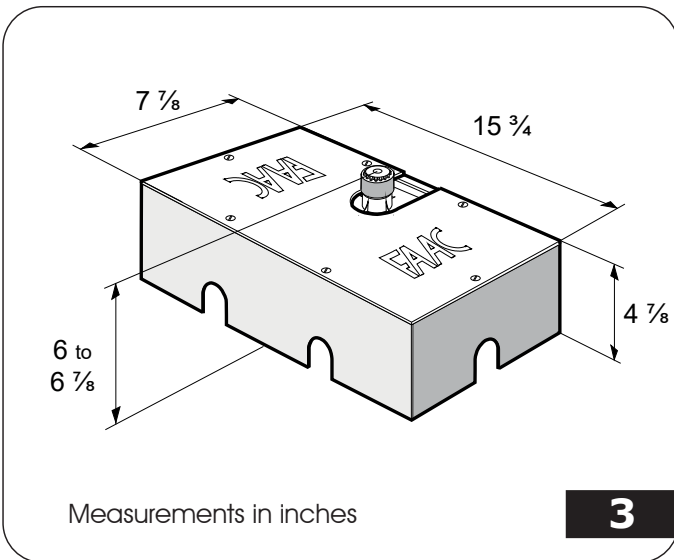

2.2 INSTALLING THE DRIVE UNIT

1) Dig a foundation hole as shown in fig.4.

To avoid having to create holes at the base of the post, we recommend to keep a minimum distance between the rotation axis of the hinge and the post of 2.4 in (60mm) (fig.6/a).

Insure that the cavity where the drive unit is located is well drained by means of pipes, gravel drainage, or both, whatever is appropriate for your soil conditions.

2) Bend the foundation plate anchor bolts.

3) After the concrete is poured in the form and before it has a chance to set, insert the foundation plate into the cement and position it so that it is flush with the top of the concrete and is level as shown in fig.5/a-b.

Allow the concrete to set a minimum of two full days before you install the drive unit on top of it.

4) Install a 1-1/4" PVC conduit for the hydraulic lines that reaches

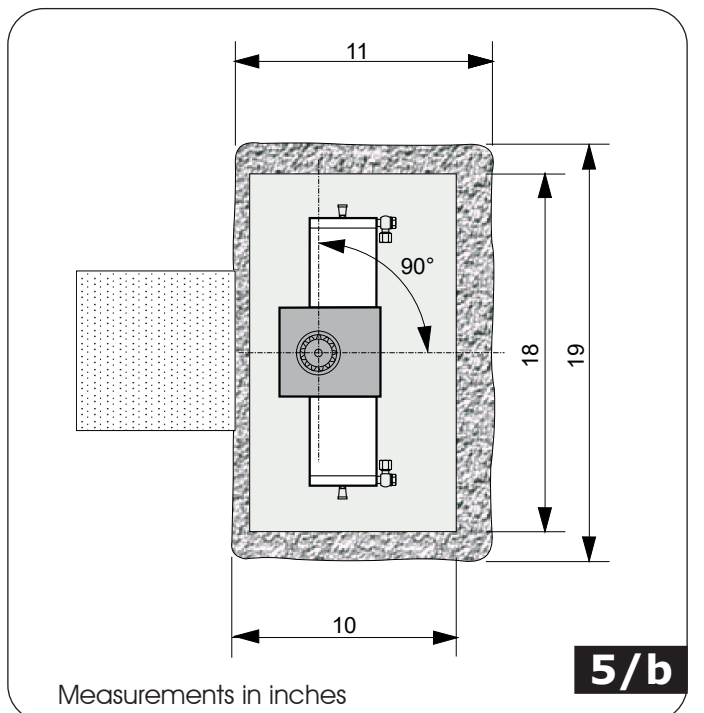
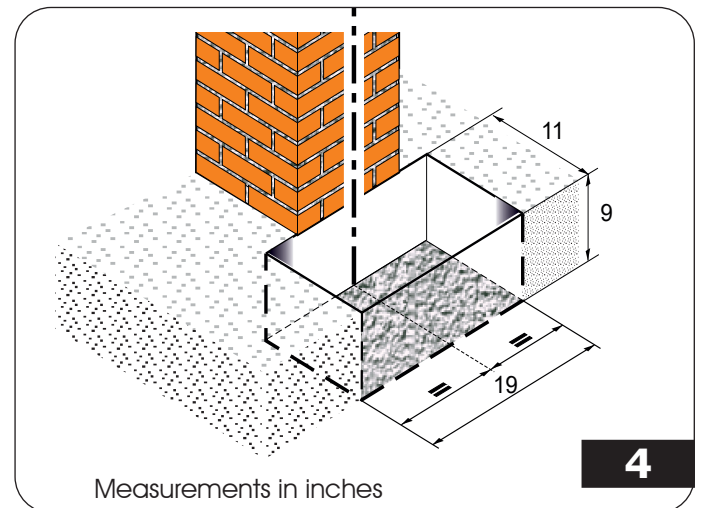

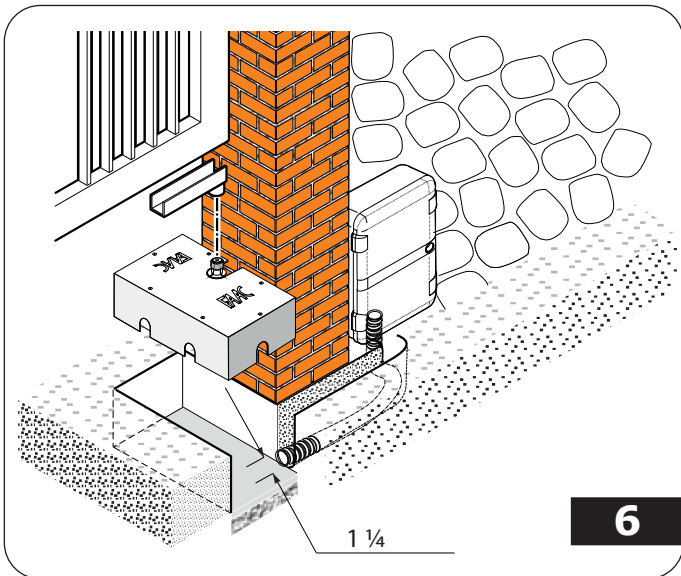

6

the hydraulic control unit (fig.6).

The path of the conduit must have wide bends to facilitate the routing of the hydraulic lines (fig.7).

5) Place the drive unit on the foundation plate as shown in fig. 5/a-b, and ensure that it is not resting on the levelling set screws (fig.2 - ref.7).

**Make sure that the center of the splined shaft is vertically aligned with the center of the gate hinge axis (use a plumb line)**

6) Place the provided C-brackets at the base of the drive unit and weld directly to the foundation plate as shown in fig.8.

**⚠ Do not weld the base of the jack to the foundation plate or to the C-bracket.**

7) Prepare the two L-shaped "box halves" for installation. Note that the lip on each piece should be on top so as to support the top cover. Make the necessary holes for the two hydraulic lines that run from the drive unit to the power unit

8) Weld the box halves to the foundation plate and to one another so as to enclose the drive unit on four sides. Be sure to protect the drive unit during welding.

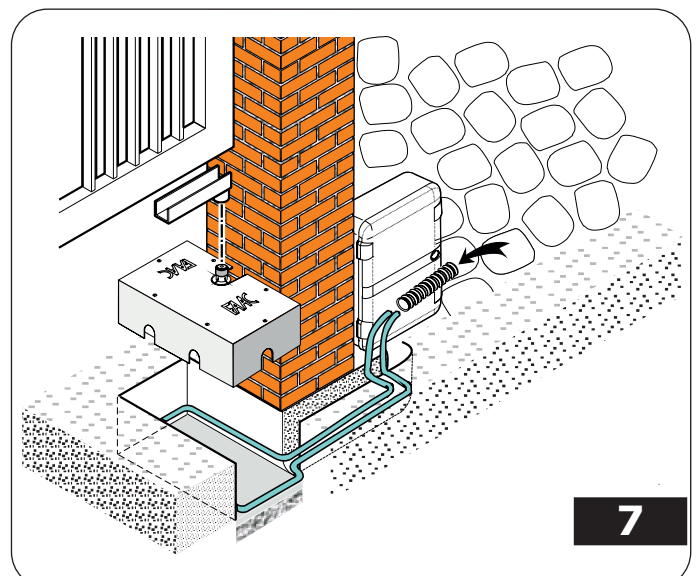

7

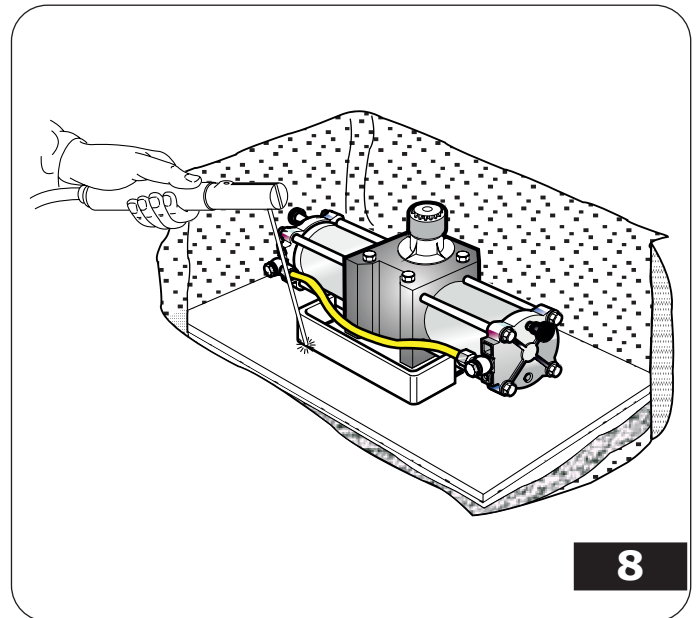

8

**2.3 INSTALLING THE HYDRAULIC CONTROL UNIT**

1) Place the control unit box as close as possible to the drive unit. The maximum distance is 65 ft (20 m). The box can be surface mounted to a wall (fig.10) or recessed (fig.11).If you recess the box, keep in mind that hydraulic hoses and electrical wiring need to enter from the bottom

2) The control unit box ships with hinges on the left, but the opening can be reversed if necessary To reverse the opening direction, open the cover, and then gently pull it off the box. The hinges can now be placed in the hinge receptacles on the right-hand side. **Be extremely cautious when doing this to avoid damaging the hinges.** Secure the hinges with the screws provided.

3) Route the electrical cable and hydraulic lines using the 4 knock-out holes on the bottom.

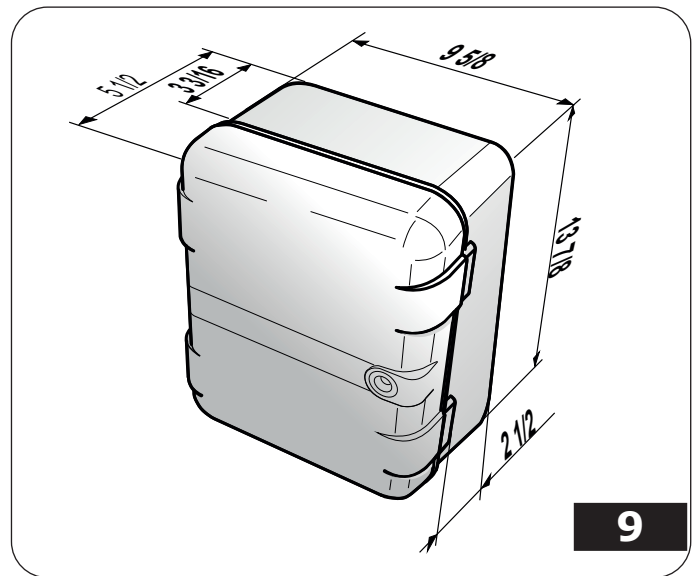

9

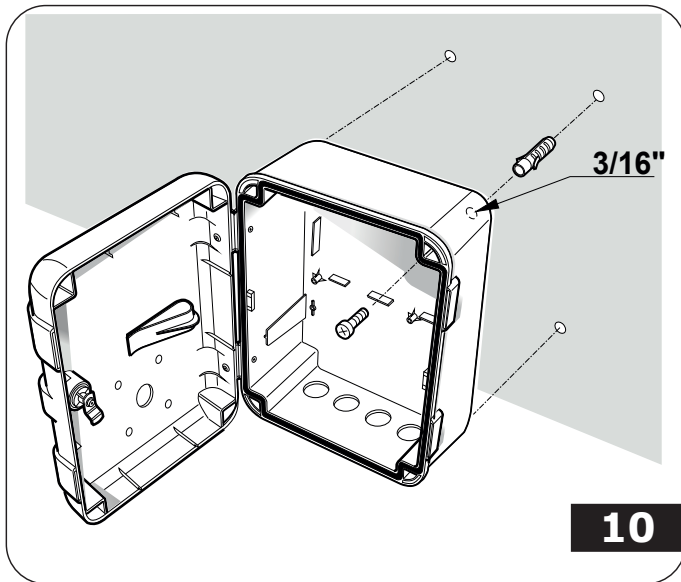

10

**2.4 HYDRAULIC CONNECTION**

The drive unit and hydraulic control unit are connected by two hydraulic lines, each with an outside diameter of 5/16 in. (0.8 cm), an inside diameter of 5/32 in. (0.4 cm), and a 2,500 psi (170 bar) rating).

Caution: After removing the nylon piping on the drive unit do not rotate the splined shaft while you are connecting the hydraulic lines to avoid squirting hydraulic fluid.

Remove the nylon piping connecting the two hydraulic pipe fittings on the drive unit. Clean up any spilled hydraulic fluid.

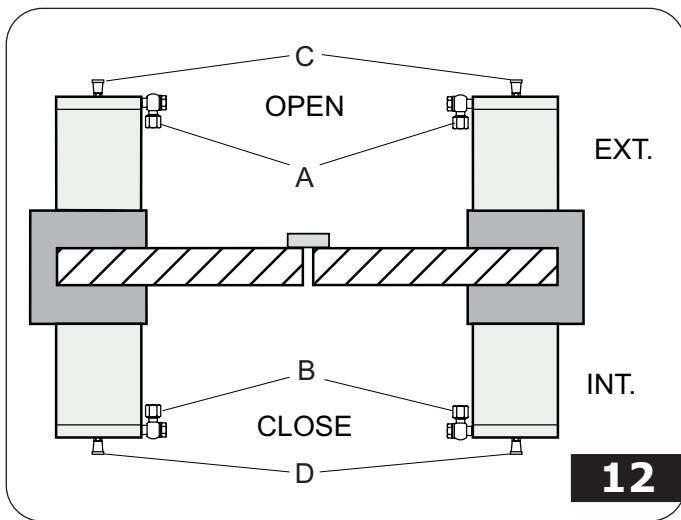

12

Be sure the hydraulic lines are free of any debris by flushing them with a jet of compressed air. Then attach one line to each fitting on the drive unit.

Attach the other end of the hydraulic lines to the pipe fittings on the hydraulic control unit (fig. 13).

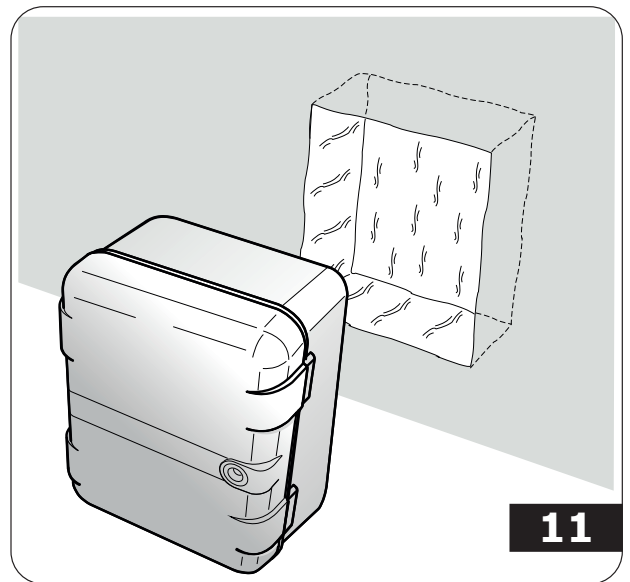

11

The control unit fitting beside the green by-pass screw must be connected to the drive unit fitting that is within the property (fig. 12-ref.B). The control unit fitting beside the red by-pass screw must be connected to the drive unit fitting that is outside the property (fig. 12-ref.A). These connections make it possible to adjust the force given to the gate when opening using the green by-pass screw and when closing using the red by-pass screw. (For inward swinging gates)

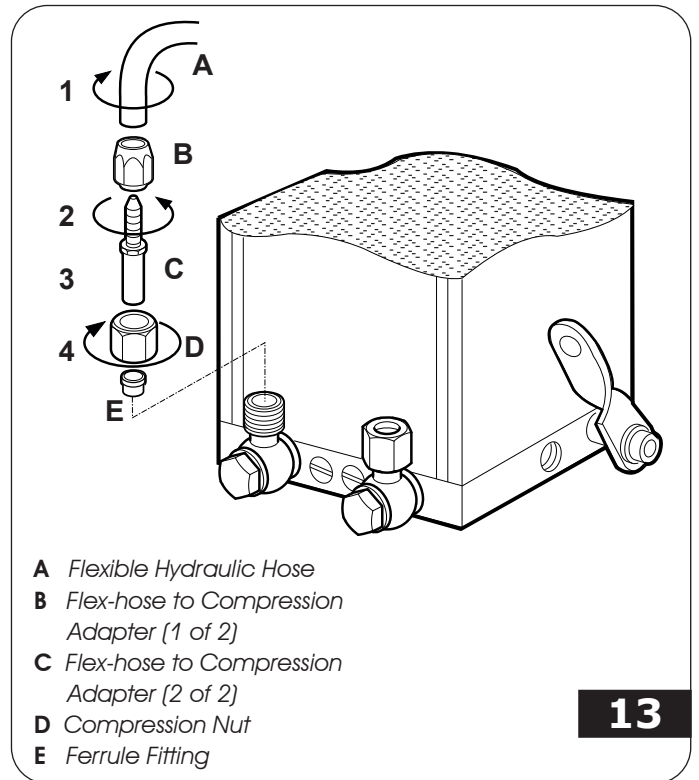

13

- A Flexible Hydraulic Hose
- B Flex-hose to Compression Adapter (1 of 2)
- C Flex-hose to Compression Adapter (2 of 2)
- D Compression Nut
- E Ferrule Fitting

**How to install the Flex Hose on the hydraulic control unit (fig. 13)**

1. Screw item B onto the hydraulic hose A (counter clock-wise) until tight.
2. Screw item C into item B & A. To get the threads to catch up, you must push C into B & A as you turn it (clock-wise)

3. Slide item D onto item C.
4. Slide item E onto item C, with larger end toward item D.
5. Insert item C into the connector on the pump unit.
6. Tighten item D securely while holding assembled adapter unit fully into connector.
7. Once you have tightened item D, item E will be permanently crimped onto item C. The hose can be removed from the pump and it will remain assembled.

Remove the control unit breather screw as shown in fig.14.

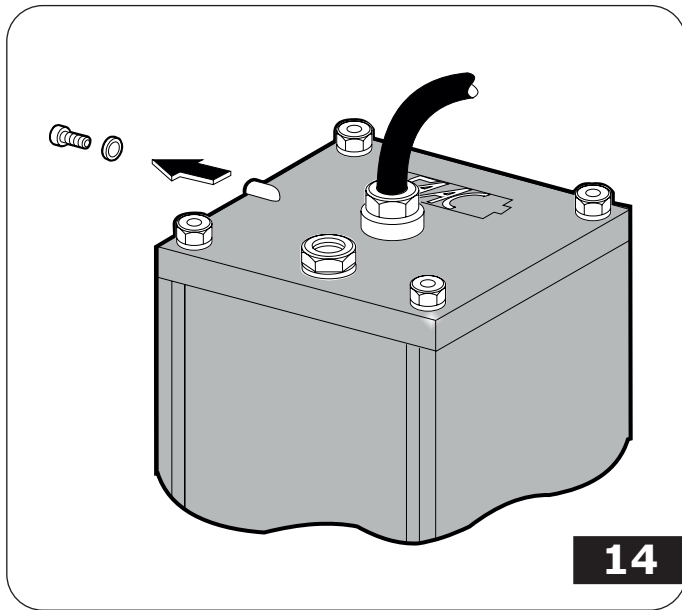

14

Top up the oil level using the references on the oil filler cap rod (fig.20). The provided FAAC HP OIL can fill a path of approximately 6 ft in length. For longer paths, complete filling use only FAAC HP OIL.

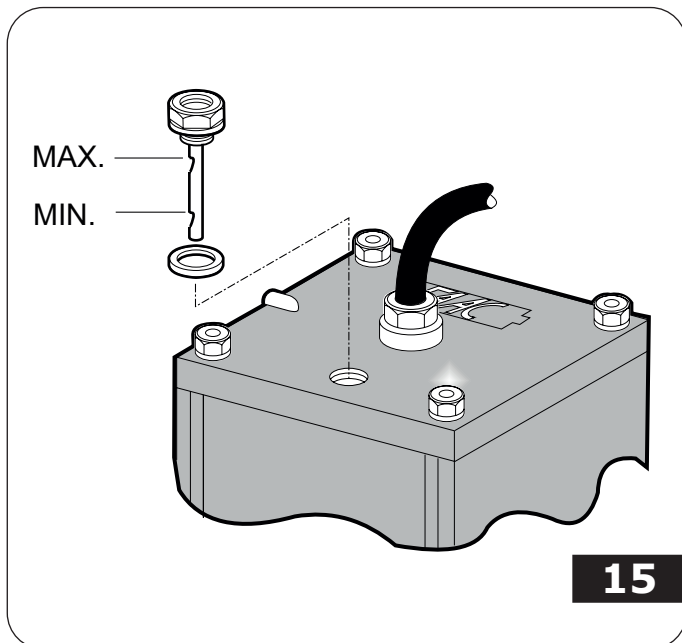

15

**2.5 AIR BLEED OPERATIONS**

When connecting the control unit and the jack, air will inevitably enter the system.

The presence of air in the hydraulic system causes irregular operation, which manifest itself with irregular movement of the leaf and excessive noise

To avoid this proceed as follows:

- 1) command opening of the gate;
  - 2) while the leaf is moving, temporarily remove the protective cap and loosen the air bleed screw for the opening movement (fig.12-ref.D) as shown in fig.16;
  - 3) release any air from the hydraulic circuit until non-emulsified oil appears;
  - 4) tighten the air bleed screw before the operator completes the opening cycle;
  - 5) command closing of the gate;
  - 6) while the leaf is moving, temporarily remove the protective cap and loosen the air bleed screw for the closing movement (fig.12-ref.C) as shown in fig.16;
  - 7) release any air from the hydraulic circuit until non-emulsified oil appears;
  - 8) tighten the air bleed screw before the operator completes the closing cycle.
- We recommend to repeat this operation a few times for each air bleed screw.
- 9) Top up the oil level using the references on the oil filler cap rod (fig.15). Top up oil using only FAAC HP OIL.

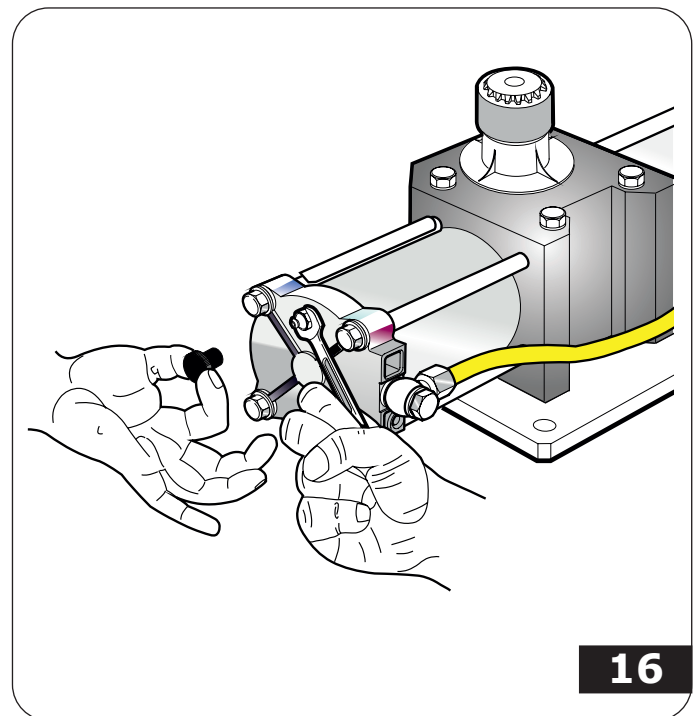

16

**2.6 INSTALLING THE GATE**

- 1) Manual release the system (see paragraph 4).
- 2) Turn the splined bushing (while on the splined shaft) in the closing direction until it stops.
- 3) To prevent the piston in the drive unit from bottoming out in its cylinder turn the splined shaft 5 degrees in the opening direction
- 4) Make the gate leaf shoe:
  - Construc the U-shaped section of the shoe as shown in fig.17;
  - Position the section on the splined bushing in the "leaf closed" position;
  - Determine the correct position of the bushing by referring to the position of the leaf with respect to the rotation axis (fig.18);
  - Spot weld the bushing to the U-section
  - Check that the system setup is correct by manually simulating complete opening;
  - Carefully weld the bushing to the section (fig.19);
  - Close the U-section, on the post side, using a plate as shown in fig.20.
- 5) Lubricate the splined shaft with grease.
- 6) Insert the leaf shoe bracket on the splined shaft in the previous "leaf closed" position.
- 7) Place the gate in the leaf shoe and hinge the top part.

**The gate must rest on the guide bracket. To increase the drive unit height, turn the levelling set screws clockwise (fig.2-ref.7).**

**⚠ To avoid compromising the correct operation of the automated system, never weld the gate leaf to the shoe bracket or directly to the splined bushing.**

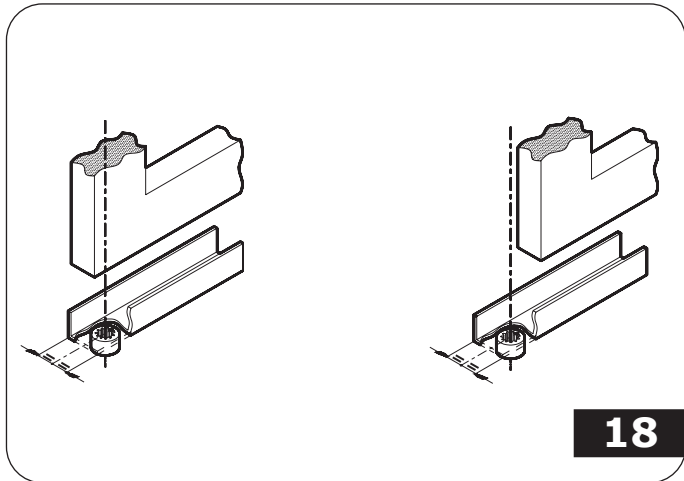

**18**

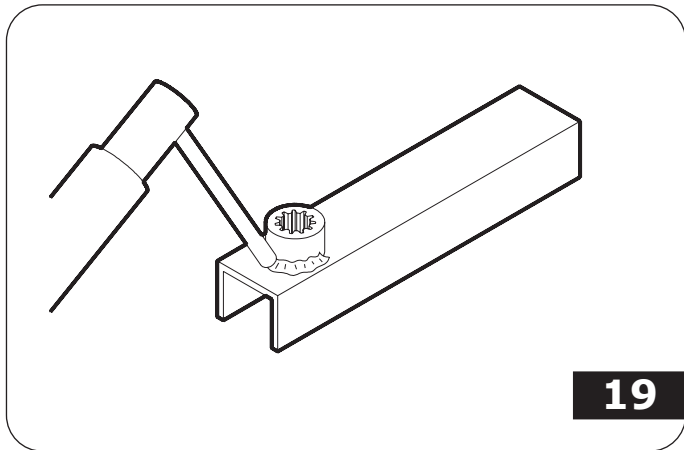

**19**

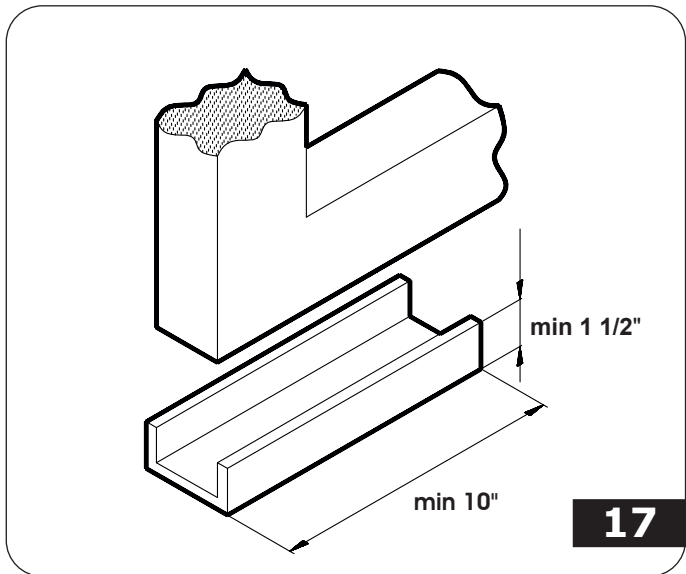

**17**

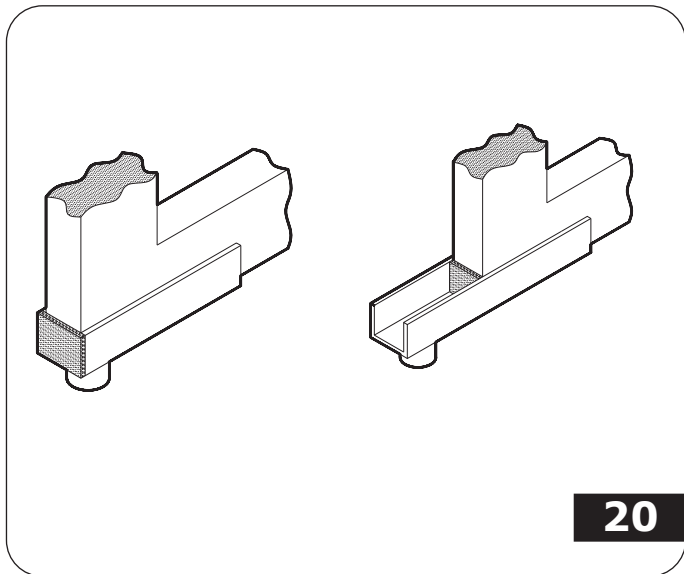

**20**

- 8) Manually check that the gate opens freely and completely, stopping on the external positive stops and that the movement of the leaf is smooth and without irregular friction.
- 9) Place the drive unit protection cover on the box as shown in fig.21.
- 10) Complete the concrete pouring around the box. To avoid possible deformation make sure that the box cover is in place

**3. FINAL OPERATIONS**

**3.1. ADJUSTING THE BYPASS VALVES**

The 750 operators features a built in anti-crushing system that guarantees to stop the gate movement in the presence of an obstacle. The anti-crushing system is adjusted using two bypass valves, one for the opening movement and one for the closing.. It's recommended to adjust the bypass valves so that the operator doesn't create more pressure on the gate than what's necessary to reliably move it.

The screws shown in fig. 22 are used to set of the bypass valve tripping threshold:

- The red screw adjusts the closing pressure of the leaf.
- The green screw adjusts the open pressure of the leaf.
- To increase pressure, turn the screws clockwise.
- To reduce pressure, turn the screws counterclockwise.

**4 MANUAL OPERATION**

Should manually operating the gate be required due to power outage or operator's problems, use the release lever as shown in fig.23.

To lock the system again move the lever back in its original position until it reaches its internal stop point.

**5 MAINTENANCE**

Periodically check the oil level using the references on the oil filler cap rod (fig.15).

Check the gate structure every 6 months.

When required, top up oil using only FAAC HP OIL.

Periodically check both the correct setting of the by-pass screws and the efficiency of the manual release system (see the corresponding paragraphs).

Periodically check the gate structure and in particular ensure that the top hinge is in perfect working condition.

The system's safety devices must be checked every 6 months.

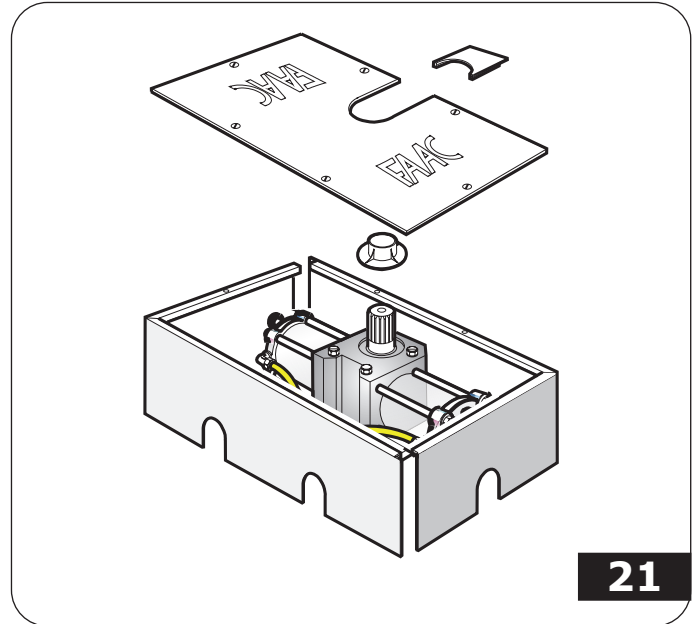

**21**

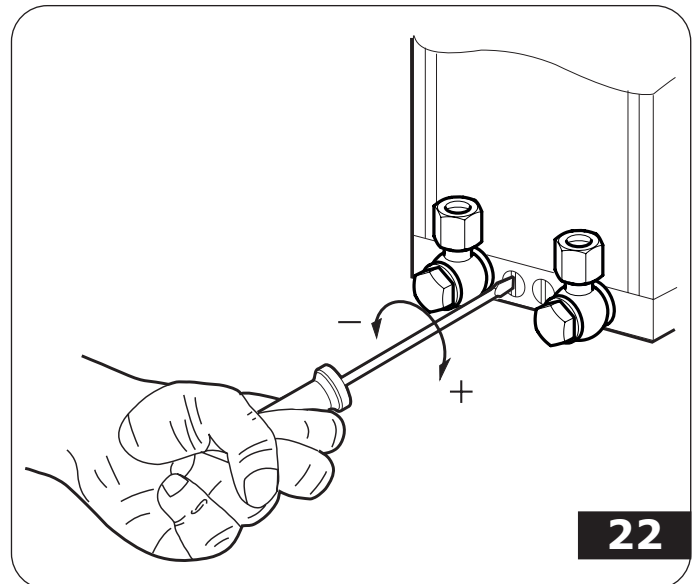

**22**

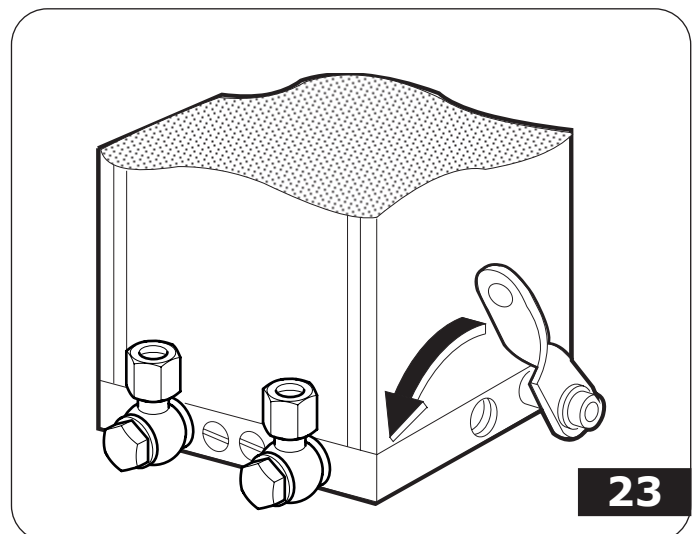

**23**

This page is intentionally left blank

# 455D CONTROL BOARD

## 1. General Description

The 455 D control board is used to operate the FAAC High Voltage swing gate operators. It has several operating logics built in, programmable with the help of a display and push-buttons. The board allows connection of various accessories including monitored photocell for compliance with the UL325 standard Ed: 7.

**The 455D control board allows the connection of 1 close and up to 2 open entrapment protection devices.**

The board should be installed in an enclosure that is conveniently located as close as possible to the gate operator. All electrical connections from the control board to the operator must be made in a weatherproof junction box.

## 2. Technical Specifications

<b>Input Voltage</b>	115 V~ ± 10% or 230 V~ +6% -10% 50/60 Hz
<b>Input Power</b>	10 W
<b>Motor Max. Load</b>	800 W
<b>Accessories Max. Load</b>	0,5 A
<b>Electric Lock Max. Load</b>	15 VA
<b>Ambient Operating Temperature Range</b>	-4°F to +131°F
<b>Protection Fuses</b>	5A (230V version) 10A (115V Version) 800 mA (accessory)

## 3. Features

### Function Logics:

Semi-automatic / Automatic / Safety Devices / "Stepped" Semi-automatic / "Stepped" Automatic / "Stepped" Safety Devices / Semi-automatic B / Dead-man C

### Opening/Closing Time:

Programmable (from 0 to 120 s)

### Pause Time:

Programmable (from 0 to 4 min.)

### Closing Leaf Delay:

Programmable (from 0 to 4 min.)

### Opening Leaf Delay:

2 s (can be excluded)

### Thrust Force:

Adjustable on 50 levels for each motor

### Terminal Board Inputs:

Open / Open Free Leaf / Stop / Limit-switch / Opening Safety Devices / Closing Safety Devices / Power Supply + Earth.

### Terminal Board Outputs:

Flashing Lamp / Motors / 24 VDC Accessories Power Supply / 24 VDC Indicator-Light / Fail Safe / 12 VAC Electric Lock Power Supply

### Programmable Functions:

Logic / Pause Time / Thrust Force / Torque at Initial Thrust / Opening and Closing Leaf Delay / Reversing Stroke / Over-Pushing Stroke / Indicator-Light / Pre-Flashing / Electric Lock / Fail Safe / Safety Devices Logic / Assistance Request / Detection Time of Obstacle or Contact Point

### Learning Function:

Simple or complete work time learning, with or without Limit-switches

## 4. Layout and Components

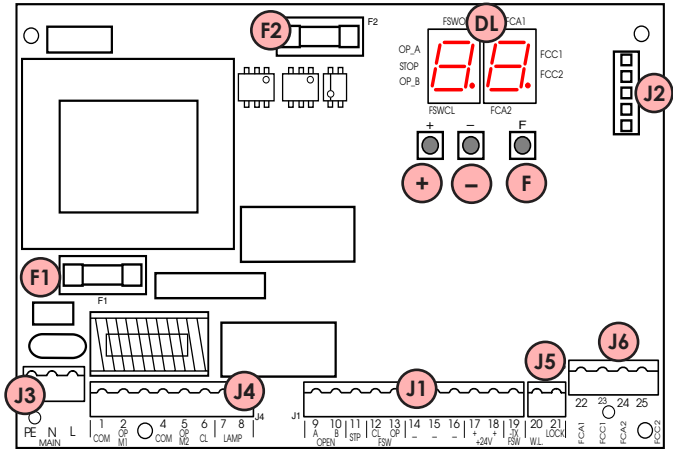

**DL** STATUS AND PROGRAMMING DISPLAY

**J1** LOW VOLTAGE TERMINAL BLOCK

**J2** CONNECTOR FOR RADIO RECEIVER

**J3** AC POWER SUPPLY TERMINAL BLOCK

**J4** MOTORS AND WARNING LAMP TERMINAL BLOCK

**J5** INDICATOR-LIGHT AND ELECTRIC LOCK TERMINAL BLOCK

**J6** LIMIT-SWITCH TERMINAL BLOCK

**F1** MOTORS AND TRANSFORMER PRIMARY WINDING FUSE (F 5A - 230V) (F 10A - 115V)

**F2** LOW VOLTAGE AND ACCESSORIES FUSE (T 800mA)

**F** "F" PROGRAMMING PUSH-BUTTON

- "-" PROGRAMMING PUSH-BUTTON

+ "+" PROGRAMMING PUSH-BUTTON

### Connector J2 - Rapid Connection to RP Receivers

The 5 pin J2 connector allows to plug in the FAAC RP radio receivers

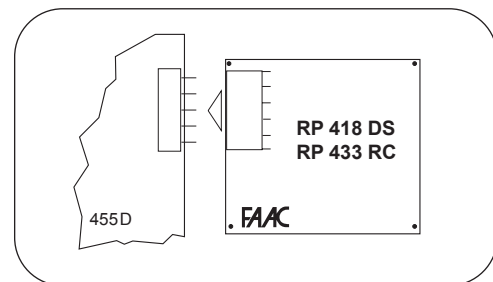

### Terminal Block J3 - Power Supply

**PE:** Earth Connection / Ground

**N:** AC V~ power supply (Neutral)

**L:** AC V~ power supply (Line)



The installer is responsible for grounding the operator system, for providing the main power breaker switch, and for making sure that the entire gate system meets all applicable electrical codes.

5. Electric Connections

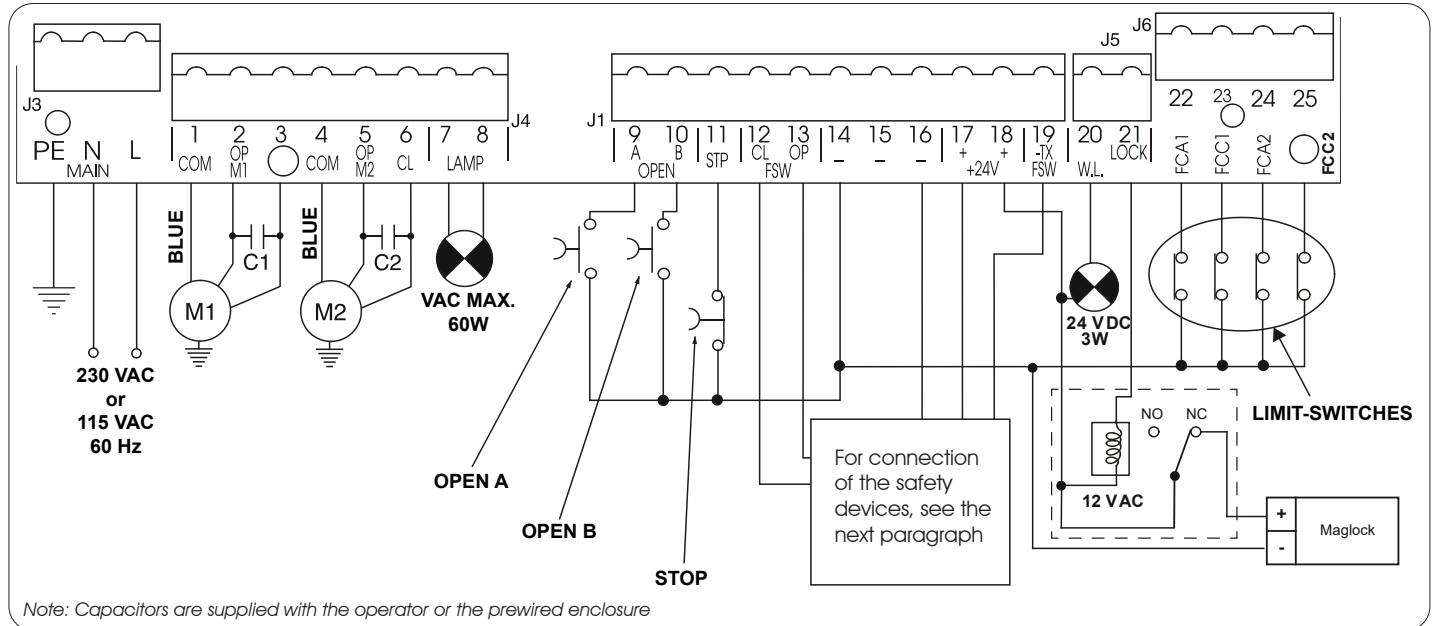

Note: Capacitors are supplied with the operator or the prewired enclosure

**Terminal Block J4 - Motors and Warning Lamp**

**M1:** COM / OP / CL: Connection to Motor 1  
**Must be used for single-leaf configuration**

**M2:** COM / OP / CL: Connection to Motor 2  
**Cannot be used in single-leaf configurations**

**LAMP:** Warning lamp output ( AC V ~)

**Terminal Block J1 - Accessories**

**OPEN A - "Total Opening" Command (N.O.):**

Any pulse generator (push-button, detector, etc.) which, by closing a contact, commands opening and/or closing of both gate leaves. To install several full opening pulse generators, connect the N.O. contacts in parallel.

**OPEN B - "Partial Opening" Command (N.O.) / Closing:**

Any pulse generator (push-button, detector, etc.) which, by closing a contact, commands opening and/or closing of the leaf driven by motor M1. In the B and C logics, it always commands closing of both leaves. To install several partial opening pulse generators, connect the N.O. contacts in parallel. See logic chart for exact operation.

**STP - STOP Contact (N.C.):**

Any device (e.g. a push-button) which, by opening a contact, is able to stop gate movement. To install several STOP devices, connect the N.C. contacts in series. It also can act as an additional monitored opening safety.

**Note: If STOP devices are not used, connect a jumper between the STP terminals and -.**

**CL FSW - Closing Safety Contact (N.C.):**

The closing safety input is used to protect the leaf movement area during closing. While closing, an activation of the the safety device connected to this input will reverse the movement of the gate leaves. This input is inactive during the opening cycle. To be compliant with the UL325 standard **at least one monitored safety device must be connected to this input.** See the next paragraph on how to connect a monitored device. If this input is active when the gate is open it will prevent the leaf closing movement.

**OP FSW - Opening safety devices contact (N.C.):**

The opening safety input is used to protect the leaf movement area during opening. While opening, an activation of the the safety device connected to this input will reverse the movement of the gate leaves. This input is inactive during the closing cycle. To be compliant with the UL325 standard if this input is used to protect an entrapment zone at least one monitored safety device must be connected to it. See the next paragraph on how to connect a monitored device. If this input is active when the gate is closed it will prevent the leaf opening movement.

**= - Negative for power supply to accessories**

**± - 24 VDC - Positive for power supply to accessories**

**Important:** Accessories max. load is 500 mA. To calculate current draw, refer to the instructions for individual accessories.

**-TX FSW - Negative Power to photocell transmitters.**

This terminal is used for the photocells monitoring feature. Compliance with the UL325 standard requires connecting the transmitter photocell negative power to this input and activating the FAIL SAFE function (see *Advanced Programming*). This will allow the 455 D board to check the correct operation of the safety photocells before each opening or closing cycle.

**Terminal Block J5 - Indicator-Light and Electric Lock**

**W.L. - Power supply to indicator-light**

Connect a 24 VDC - 3 W max. indicator-light, if necessary, between this terminal and the +24V supply. To avoid compromising correct operation of the system, do not exceed the indicated power.

**LOCK - Power supply to electric lock**

If necessary, connect a 12 Vac electric strike lock between this terminal and the +24V power supply. Or connect a 12 Vac relay and a Maglock following the schematic above.

**Terminal Block J6 - Limit-Switches**

These inputs are dedicated to the connection of opening and closing limit switches

**6. Connection of Safety devices**

**Entrapment protection**

To comply with the UL325 standard for gate operators every entrapment zone, as defined in ASTM F2200, must be protected by two independent entrapment protection devices. One of the devices is inherent in the FAAC operators or the control board design, the other can be external, like a photocell or an edge sensor.

See the following picture for the photocells positioning:

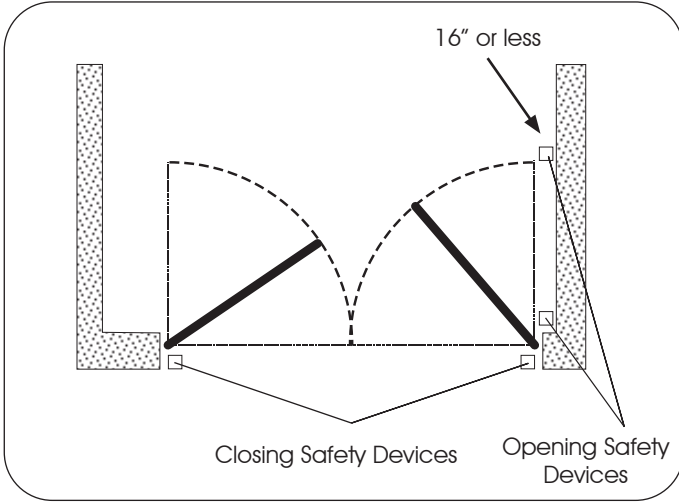

**Opening Safety Devices:**

Are active only during the gate opening movement, and are suitable for protecting the area between the opening leaves and fixed obstacles (walls, etc) against the risk of entrapment

**Closing Safety Devices:**

Are active only during the gate closing movement, and are suitable for protecting the closing area against the risk of entrapment.

**Monitored Devices:**

Additionally the UL325 standard requires that every external entrapment protection device must be monitored for presence and correct operation. The closing safety devices are always monitored, see the following picture for the wiring of a pair of photocells as closing safety devices.

**NOTE: one closing safety device must always be connected for the system to work.**

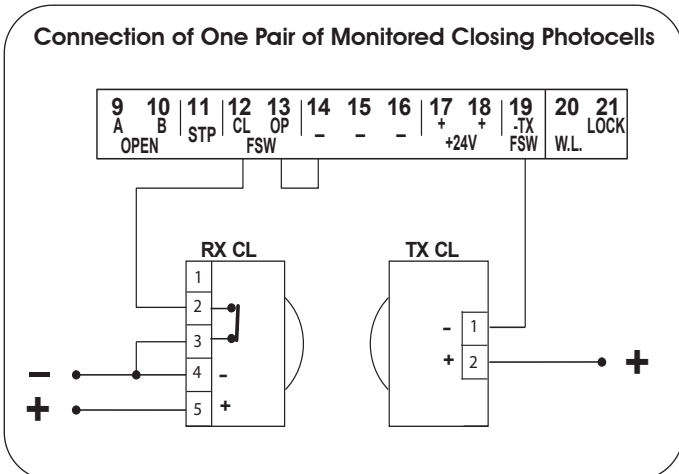

Monitoring of the opening safety devices must be enabled in the board configuration. To enable it enter in advanced programming by pressing and holding "F" and then press "+", scroll to the "FS" parameter and select "Active".

**ADVANCED PROGRAMMING** (F) + (+)

Display	Function	Default
FS	<p><b>OPENING FAIL SAFE:</b></p> <p>If this function is activated, it enables the monitoring of the opening safety photocell before the opening movement. If the test fails the gate does not open.</p> <p>4 = Active    n0 = Disabled</p>	n0

**Connection of One Pair of Monitored Closing Photocells and One Pair of Monitored Opening Photocells**

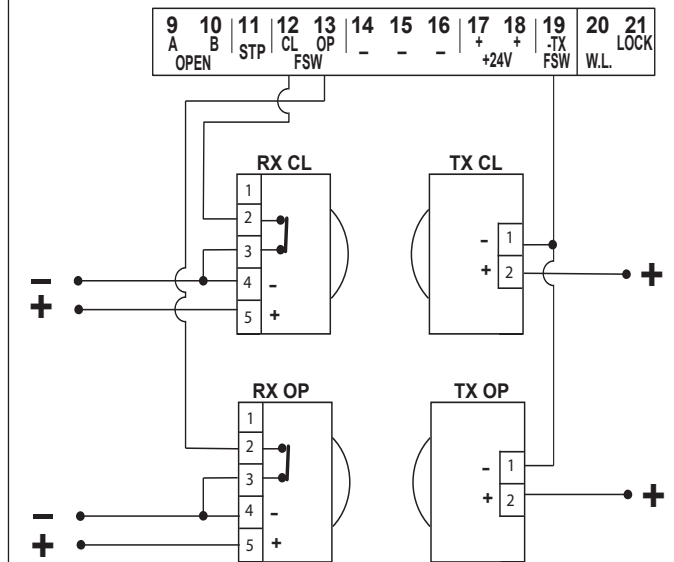

If an additional monitored opening safety device is needed it can be connected to the STP input. The "OP" parameter in the board configuration must be set to active

**Connection of One Pair of Monitored Opening Photocells**

**OP** **OPENING No. 2 FAIL SAFE:**

When enabled the STOP input can be used for the connection of a second monitored opening safety device.

4 = Active    n0 = Disabled

**NOTE:** If present remove the jumper from Pin 11

Only one monitored photocell can be connected to the Closing or Opening safety inputs. More than one photocell or other device can be connected to the safety inputs, but they will not be monitored.

Other devices connected to the safety inputs must have normally closed contacts and wired in series with the main monitored sensor.

See the following example of one closing safety monitored photocell and one non monitored one.

See the following connections diagrams for example of opening/closing safety wiring.

**Connection of Two Pairs of Closing Photocells, One Monitored and One Non Monitored**

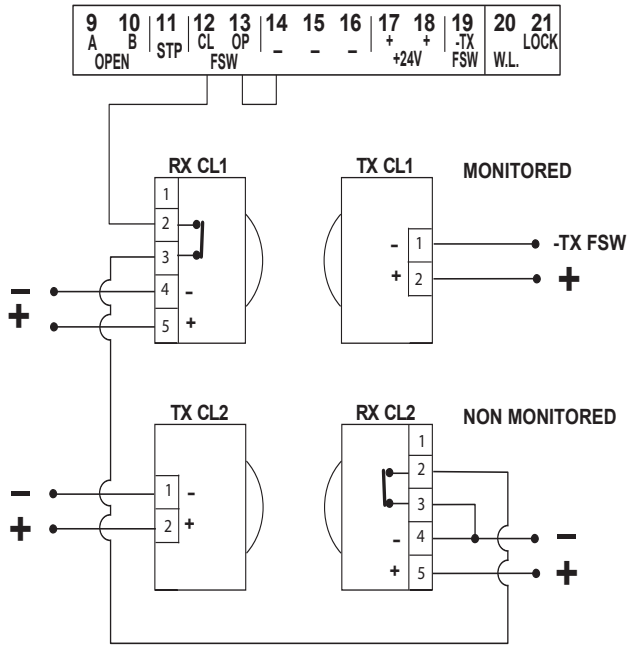

**Connection of a pair of Monitored Closing Photocells, and one pair of Non Monitored Opening/Closing Photocell**

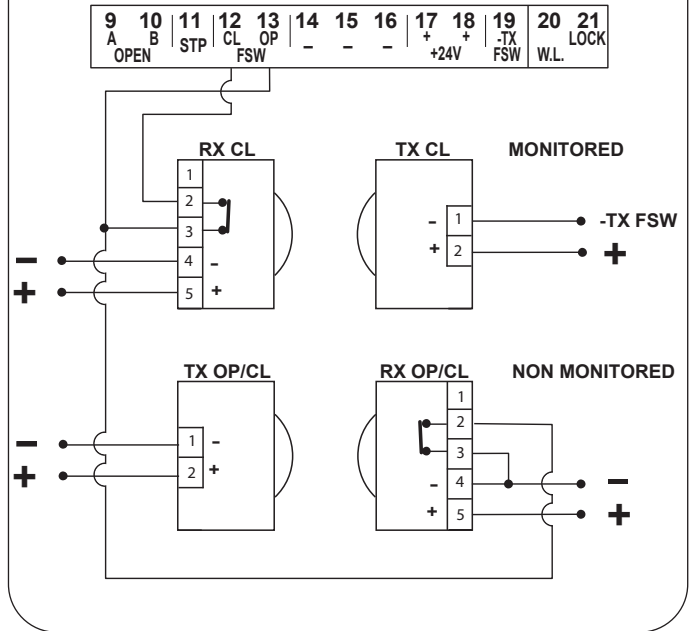

**Connection of One Pair of Monitored Closing Photocells, One Pair of Monitored Opening Photocells and One pair of Non Monitored Opening/Closing Photocells**

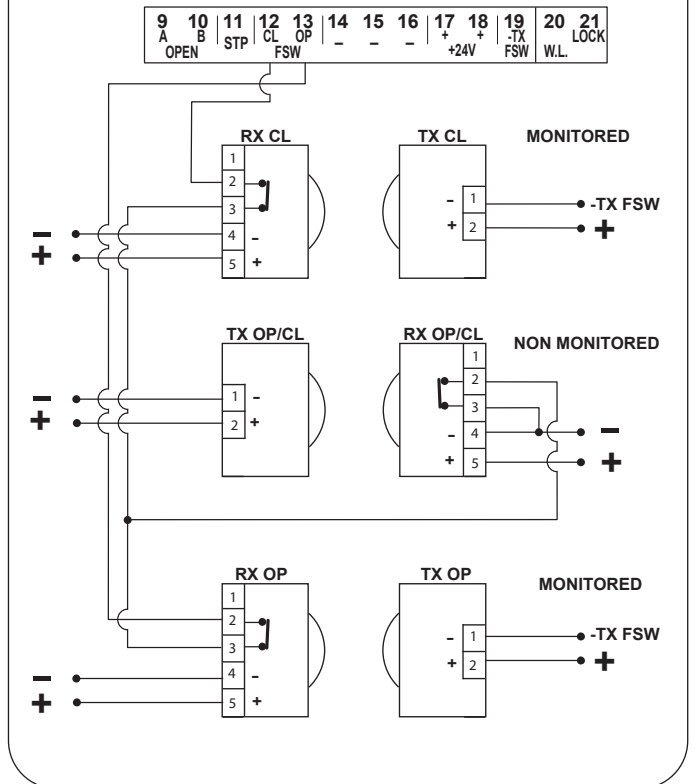

**Opening/Closing Safety Devices:**

They operate during the gate opening and closing movements and are suitable to protect the opening and closing areas against the risk of impact. Typically these photocells work in combination with other monitored photocell protecting closing or opening entrapment zones. In that case they can't be monitored so they can only protect against potential impact on vehicles.

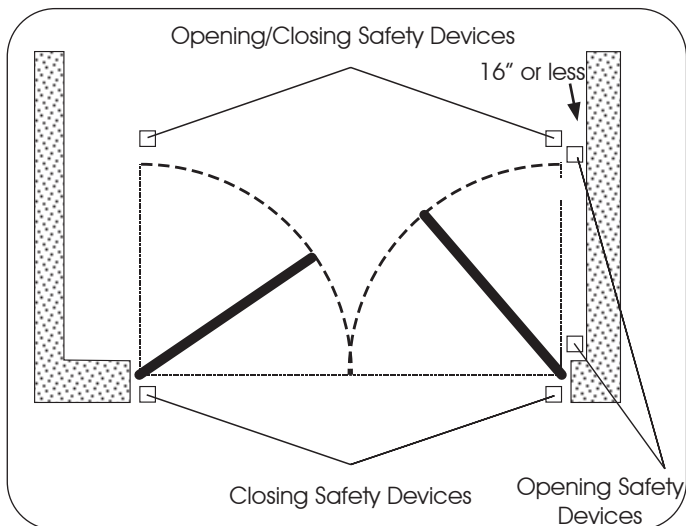

**7. Operating Logics**

This is a brief description of the main operating logics of the system. For a complete description please refer to Table 3

- E (semi-automatic): This mode requires a command to open and a command to close. A second command during opening stops the gate. A second command during closing reopens the gate.
- A (automatic): The gate opens on command and automatically closes after the pause time. A second command while opening is ignored; a second command during the pause phase interrupts the pause time; a second command during closing reopens the gate. A maintained open command will hold the gate open.
- S (security): The security mode is like A logic except that a second command during opening immediately closes the gate. A maintained open command will not hold the gate open.
- EP (semi-automatic, step by step): This mode requires a command to open and a command to close. A second command during opening or closing causes the gate to stop. A third command then reverses the previous motion of the gate.
- B (manned, pulsed): This mode is designed for guard station use and requires a three button switch (pulsed) to open, close, and stop the gate.
- C (manned and constant): This mode requires constant pressure switches. One to open and one to close. No pressure on a switch stops the gate.

**8. Programming**

To program the 455D Control Board, you have to access "PROGRAMMING" mode. Programming is split into two parts: BASIC and ADVANCED.

**Basic Programming:**

To access BASIC PROGRAMMING, press key **F**:

- Press and hold **F**, the unit will display the name of the first function / parameter.
- When you release the key, the unit will display the parameter's current value.
- Value can be modified with keys + and - .
- Press and hold **F** again, the unit will display the name of the next function / parameter.
- When you reach the last function, press **F** to exit the program, the display resumes monitoring input status.
- IMPORTANT: Make sure to exit programming mode otherwise the changes will not be saved.

The following table displays the sequence of functions accessible in BASIC PROGRAMMING:

BASIC PROGRAMMING <small>press <b>F</b></small>		
Display	Function	Default
LO	<b>OPERATING LOGICS (see tab. 3/a - h):</b> E = Semi-automatic A = Automatic S = Security EP = "Stepped" Semi-automatic AP = "Stepped" Automatic SP = "Stepped" Security b = Manned, pulsed c = Manned, constant	E
PA	<b>PAUSE TIME:</b> This has effect only when automatic logic is selected. Adjustable from 0 to 59 secs. in one-second increments.  Subsequently, display changes to minutes and tenths of seconds (separated by a decimal point), time is adjusted in 10-second increments, up to 4.1 minutes max. Thus, if the unit displays 2.5, Pause Time is 2 mins. and 50 secs.	0
F1	<b>LEAF 1 FORCE:</b> Adjusts thrust of Motor 1. 1 = minimum force 50 = maximum force (*)	25
F2	<b>LEAF 2 FORCE:</b> Adjusts thrust of Motor 2. 1 = minimum force 50 = maximum force (*)	25
cd	<b>LEAF 1 CLOSING DELAY:</b> Delays closing start of leaf 1 with respect to leaf 2. Adjustable from 0 to 4.1 minutes (see Pause Time).	0
EL	<b>TIME LEARNING (see Section 10):</b> Enables the selection between "simple" learning and "complete" (manual choice of deceleration and stop points) learning.  Simple Learning: (+) ≈ 1 s. Complete Learning: (+) > 3 s.	
in	Exit from programming and return to inputs status monitoring.	

(\*) For hydraulic operators, set force to the maximum level.

**Advanced Programming:**

To access ADVANCED PROGRAMMING, press and hold key F and then press key +:

- Release key +, the unit displays the name of the first function.
- Release key F, modify the value of the function with keys + and -.
- Press and hold key F, the unit displays the name of the next function, and if you release it, the value that can be modified with keys + and -.
- When you reach the last function, press F to exit the program, the unit resumes monitoring input status.

The following table shows the sequence of functions accessible in ADVANCED PROGRAMMING:

ADVANCED PROGRAMMING (F) + (+)		
Display	Function	Default
60	<b>MAXIMUM TORQUE AT INITIAL THRUST:</b> The motors operate at maximum torque (ignoring the torque setting) at start of movement. Useful for heavy leaves. 4 = Active no = Disabled	no
CS	<b>LAST STROKE AT CLOSING:</b> The motors are activated at full speed for 1 second to facilitate locking of the electric lock. 4 = Active no = Disabled	no
RS	<b>REVERSING STROKE:</b> Before opening, while the gate is closed, the motors thrust to close for 2 seconds thus facilitating release of the electric lock. 4 = Active no = Disabled	no
OD	<b>LEAF 2 OPENING DELAY (2 s):</b> Enables delayed start (at opening) of leaf 2, avoiding interference between leaves. 4 = Active no = Disabled	no
FS	<b>OPENING FAIL SAFE:</b> If this function is activated, it enables the monitoring of the opening safety photocell before the opening movement. If the test fails the gate does not open. 4 = Active no = Disabled	no
PF	<b>PRE-FLASHING (5 s):</b> Activates the flashing lamp for 5 seconds before start of movement. 4 = Active no = Disabled	no
EL	<b>ELECTRIC LOCK ON LEAF 2:</b> For using the electric lock on leaf 2 instead of on leaf 1. 4 = Active no = Disabled	no

Display	Function	Default
SP	<b>INDICATOR-LIGHT:</b> 0 : the output functions as a standard indicator-light (ON at opening and pause, flashing at closing, and OFF when gate is closed). 1 : the output is ON when the gate is open or in pause. OFF in all other conditions. 2 : the output is ON when the gate is closed. OFF in all other conditions. All other values correspond to the extra time compared to normal work time (opening or closing) when the output can be used - via a relay - to power a courtesy light. Time can be adjusted from 1 to 59 sec. in 1 sec. steps, and from 10 to 41 min. in 10 sec. steps.	0
Ph	<b>CLOSING PHOTOCELLS REVERSE AT RELEASE:</b> Enable this function if you want the closing photocells to stop movement and reverse at release. Default setting is immediate reverse. 4 = Active no = Disabled	no
OP	<b>OPENING No. 2 FAIL SAFE:</b> When enabled the STOP input can be used for the connection of a second monitored opening safety device 4 = Active no = Disabled	no
AS	<b>ASSISTANCE REQUEST (combined with next function):</b> If activated, at the end of countdown (settable with the next function i.e. "Cycle programming") it affects 8 s of pre-flashing at every Open pulse (job request). Can be useful for setting scheduled maintenance jobs. 4 = Active no = Disabled	no
nC	<b>CYCLE PROGRAMMING:</b> For setting countdown of system operation cycles. Settable (in thousands) from 0 to 99 thousand cycles. The displayed value is updated as cycles proceed. This function can be used to check use of the board or to exploit the "Assistance request".	0
EC	<b>EXTRA WORK TIME:</b> If reversing occurs, and if the leaf does not reach its end contact point, you can activate this function to increase work time. 4 = Active no = Disabled	no
In	Exit from programming and return to inputs status monitoring.	

**NOTE:** Parameter modifications take effect immediately. Exit out of programming to save changes. If the equipment is powered down before returning to normal status monitoring, any unsaved modifications will be lost.

To restore programming defaults, press and hold the three buttons +, -, F simultaneously for 5 seconds.

9. Start-up

**LED Indicators:**

The board has a two-digit display. When not in "PROGRAMMING" mode, this display is used to indicate the status of inputs. The figure below shows how the LED segments are mapped to the corresponding inputs.

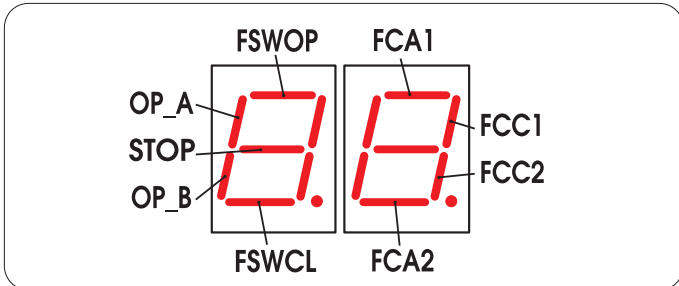

The table below shows the status of the LEDs in relation to the status of the inputs.

Note the following: **LED ON** = closed contact  
**LED OFF** = open contact

**Operation of the Status Signaling LEDs**

LEDs	ON	OFF
OP_A	Command activated	<b>Command inactive</b>
OP_B	Command activated	<b>Command inactive</b>
STOP	<b>Command inactive</b>	Command activated
FSWCL	<b>Safety devices clear</b>	Safety devices triggered
FSWOP	<b>Safety devices clear</b>	Safety devices triggered
FCA1 (if used)	<b>Limit switch free</b>	Limit switch triggered
FCC1 (if used)	Limit switch free	<b>Limit switch triggered</b>
FCC2 (if used)	Limit switch free	<b>Limit switch triggered</b>
FCA2 (if used)	<b>Limit switch free</b>	Limit switch triggered

The status of the LEDs while the gate is closed at rest are shown in bold.

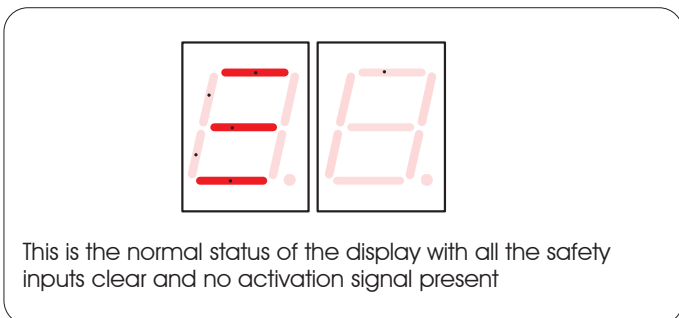

**Rotation direction and force check:**

1. Program the functions of the 455 D control board according to need, as previously shown.
2. Turn power off to the control board.
3. Release the operators and manually move the gate to the mid-point of the opening angle.
4. Re-lock the operators.
5. Restore power.
6. Send an opening command on the OPEN A input and verify that the gate leaves start moving towards the open position

**Note: If the first OPEN A pulse starts a closing movement, turn power off and reverse the phases of the electric motor (red and black wires) on the 455 D control board.**

7. Check force setting of the motors, modify if necessary.

**Note: For hydraulic operators, like the 400, force should be programmed to maximum level (50)**

8. Stop leaf movement with a pulse on the STOP input or turning off power.
9. Release the operators, close the leaves and re-lock the operators.

Opening/closing time is established by a time learning procedure which can be accomplished in "simple" or "complete" modes. The simple mode doesn't allow a slow down phase in the operator, while the complete mode does.

The slow down can be useful to reduce the mechanical stress on the gate, but it can create problems in high wind conditions.

## 10. Learning Operating Times



**WARNING:** *During the learning procedure, safety devices are disabled! Avoid crossing the leaf movement area when this operation is carried out.*

**Make sure travel limit mechanical stops are present.**

### - SIMPLE LEARNING (Without Slow Down):

Check that the leaves are closed. Enter "BASIC PROGRAMMING," select the TIME LEARNING function and then press the + push-button for **1 second**. The display begins flashing and the leaves begin to open.

As soon as the leaves reach the opening contact point, provide an OPEN A pulse (with the key operated push-button or with the radio control) to stop the movement. The leaves stop and the display stops flashing.

Press push-button **F** to exit and save the programming. The procedure is complete and the gate is ready to operate.

### - COMPLETE LEARNING (With Slow Down):

Check that the leaves are closed. Enter "BASIC PROGRAMMING," select the TIME LEARNING function and then press the + push-button for more than **3 seconds**. The display begins flashing and leaf 1 begins to open. The following functions can be performed by sending OPEN A pulses (by key push-button or radio control).

A total of 8 OPEN A commands required:

1. Slow down at opening of leaf 1
2. Leaf 1 stops at opening and leaf 2 begins its opening movement
3. Slow down at opening of leaf 2
4. Leaf 2 stops at opening and immediately begins its closing movement
5. Slow down at closing of leaf 2
6. Leaf 2 stops at closing and leaf 1 begins its closing movement
7. Slow down at closing of leaf 1
8. Leaf 1 stops at closing

When the display stops flashing, press push-button **F** to exit and save the programming. The procedure is complete and the gate is ready to operate.

#### Notes:

- *If you wish to eliminate deceleration in certain stages, wait for the leaf to reach its stop-limit and supply 2 consecutive Open pulses (by 1 second).*
- *If only one leaf is present, the entire sequence must nevertheless be completed. When the leaf has finished opening, supply 5 Open pulses until the leaf begins to close, and then resume normal operation.*

## 11. Final Tests

Once programming is complete and the proper operating times are stored in the board's memory perform a complete test the system. Verify that the operator(s) run properly and, most importantly, check that force is adequately adjusted and that safety devices are operating correctly.

After simple or complete learning the board will add 3 sec. to the programmed time so the operators will run against the stops.

### Monitored safety test:

**IMPORTANT:** To make sure that the safety photocells protecting entrapment zones are monitored properly install a temporary jumper on the N.C. output of the photocell and give an OPEN A command. The gate must not move. otherwise check the wiring of the photocells and make sure that FAIL SAFE is enabled in Advanced Programming

## 12. Operating Modes Detailed Description

Tab. 3/a

PULSES						
Logic "E"	OPEN-A	OPEN-B	STOP	OPENING SAFETY DEVICES	CLOSING SAFETY DEVICES	OP/CL SAFETY DEVICE
<b>GATE STATUS</b>						
<b>CLOSED</b>	Opens the leaf	Opens single leaf		No effect (OPEN disabled)	No effect	No effect (OPEN disabled)
<b>OPEN</b>	Re-closes the leaf immediately (3)			No effect (if on part.opng. OPEN A disabled)	No effect (3) (OPEN disabled)	No effect (OPEN disabled)
<b>CLOSING</b>	Re-opens the leaf immediately		Stops operation	No effect (saves OPEN)	see paragraph 5.2.	Locks and, on release, reverses to open
<b>OPENING</b>	Stops operation (3)			Reverses to close	No effect	Locks and, on release, continues opening
<b>LOCKED</b>	Closes the leaf (with Closing Safety devices engaged, opens at the 2nd pulse) (3)		No effect (OPEN disabled)	No effect	No effect	No effect (OPEN disabled)

Tab. 3/b

PULSES						
Logic "A"	OPEN-A	OPEN-B	STOP	OPENING SAFETY DEVICES	CLOSING SAFETY DEVICES	OP/CL SAFETY DEVICE
<b>GATE STATUS</b>						
<b>CLOSED</b>	Opens the leaf and closes it after pause time (1)	Opens single leaf and closes after pause time (1)		No effect (OPEN disabled)	No effect	No effect (OPEN disabled)
<b>OPEN on PAUSE</b>	Reloads pause time (1)(3)			No effect (if on part.opng. OPEN A disabled)	Reloads pause time (1) (3)	Reloads pause time (1) (OPEN disabled)
<b>CLOSING</b>	Re-opens the leaf immediately (1)		Stops operation	No effect (saves OPEN)	see paragraph 5.2.	Locks and, on release, reverses to open
<b>OPENING</b>	No effect (1) (3)			Reverses to close	No effect	Locks and, on release, continues opening
<b>LOCKED</b>	Closes the leaf (3)		No effect (OPEN disabled)	No effect	No effect	No effect (OPEN disabled)

Tab. 3/c

PULSES						
Logic "S"	OPEN-A	OPEN-B	STOP	OPENING SAFETY DEVICES	CLOSING SAFETY DEVICES	OP/CL SAFETY DEVICE
<b>GATE STATUS</b>						
<b>CLOSED</b>	Opens the leaf and closes it after pause time	Opens single leaf and closes after pause time		No effect (OPEN disabled)	No effect	No effect (OPEN disabled)
<b>OPEN on PAUSE</b>	Re-closes the leaf immediately (3)			No effect (if on part.opng. OPEN A disabled)	On release, closes after 5" (OPEN disabled) (3)	On release, closes after 5" (OPEN disabled)
<b>CLOSING</b>	Re-opens the leaf immediately		Stops operation	No effect (saves OPEN)	see paragraph 5.2.	Locks and, on release, reverses to open
<b>OPENING</b>	Re-closes the leaf immediately (3)			Reverses to close	No effect (saves OPEN)	Locks and, on release, continues opening
<b>LOCKED</b>	Closes the leaf (3)		No effect (OPEN disabled)	No effect	No effect	No effect (OPEN disabled)

Tab. 3/d

PULSES						
Logic "EP"	OPEN-A	OPEN-B	STOP	OPENING SAFETY DEVICES	CLOSING SAFETY DEVICES	OP/CL SAFETY DEVICE
<b>GATE STATUS</b>						
<b>CLOSED</b>	Opens the leaf	Opens leaf for the partial opening time		No effect (OPEN disabled)	No effect	No effect (OPEN disabled)
<b>OPEN</b>	Re-closes the leaf immediately (3)			No effect (if on part.opng. OPEN A disabled)	No effect (OPEN disabled) (3)	No effect (OPEN disabled)
<b>CLOSING</b>	Stops operation		Stops operation	No effect (saves OPEN)	see paragraph 5.2.	Locks and, on release, reverses to open
<b>OPENING</b>	Stops operation (3)			see paragraph 5.2.	No effect	Locks and, on release, continues opening
<b>LOCKED</b>	Restarts movement in reverse direction (3) (always closes after a Stop)		No effect (OPEN disabled)	No effect (if it must open, it disables OPEN)	No effect (if it must close, it disables OPEN)	No effect (OPEN disabled)

(1) If maintained, it prolongs the pause until disabled by the command (timer function)

(2) If a new pulse occurs within 2 seconds after reversing, it immediately stops operation.

(3) During the partial opening cycle, an OPEN A pulse causes total opening.

NB.: Effects on other active pulse inputs in brackets.

**Tab. 3/e**

PULSES						
Logic "AP"	OPEN-A	OPEN-B	STOP	OPENING SAFETY DEVICES	CLOSING SAFETY DEVICES	OP/CL SAFETY DEVICE
<b>GATE STATUS</b>						
<b>CLOSED</b>	Opens the leaf and closes it after pause time	Opens single leaf and closes after pause time	No effect (OPEN disabled)	No effect (OPEN disabled)	No effect	No effect (OPEN disabled)
<b>OPEN on PAUSE</b>	Stops operation (3)	Stops operation (3)	Stops operation	No effect (if on part.opng., OPEN A disabled)	Reloads pause time (3) (OPEN disabled)	Reloads pause time (OPEN disabled)
<b>CLOSING</b>	Re-opens the leaf immediately			No effect (saves OPEN)	see paragraph 5.2.	Locks and, on release, reverts to open
<b>OPENING</b>	Stops operation (3)	Stops operation (3)		Reverts to close	No effect	Locks and, on release, continues opening
<b>LOCKED</b>	Closes the leaf (with Closing Safety devices engaged, opens at the 2nd pulse) (3)		No effect (OPEN disabled)	No effect	No effect	No effect (OPEN disabled)

**Tab. 3/f**

PULSES						
Logic "SP"	OPEN-A	OPEN-B	STOP	OPENING SAFETY DEVICES	CLOSING SAFETY DEVICES	OP/CL SAFETY DEVICE
<b>GATE STATUS</b>						
<b>CLOSED</b>	Opens the leaf and closes it after pause time	Opens single leaf and closes after pause time	No effect (OPEN disabled)	No effect (OPEN disabled)	No effect	No effect (OPEN disabled)
<b>OPEN on PAUSE</b>	Stops operation (3)	Stops operation (3)	Stops operation	No effect (if on part.opng., OPEN A disabled)	On release, closes after 5" (OPEN disabled)	On release, closes after 5" (OPEN disabled)
<b>CLOSING</b>	Re-opens the leaf immediately			No effect (saves OPEN)	see paragraph 5.2.	Locks and, on release, reverts to open
<b>OPENING</b>	Stops operation (3)	Stops operation (3)		Reverts to close	No effect (saves OPEN)	Locks and, on release, continues opening
<b>LOCKED</b>	Closes the leaf (3)		No effect (OPEN disabled)	No effect	No effect	No effect (OPEN disabled)

**Tab. 3/g**

PULSES						
Logic "B"	OPEN-A (opening)	OPEN-B (closing)	STOP	OPENING SAFETY DEVICES	CLOSING SAFETY DEVICES	OP/CL SAFETY DEVICE
<b>GATE STATUS</b>						
<b>CLOSED</b>	Opens the leaf	No effect	No effect (OPEN B disabled)	No effect (OPEN A disabled)	No effect	No effect (OPEN A disabled)
<b>OPEN</b>	No effect	Closes the leaf	Stops operation	No effect (saves OPEN A)	No effect (OPEN B disabled)	No effect (OPEN B disabled)
<b>CLOSING</b>	Reverts to open	No effect		Stops operation (OPEN-A disabled)	Stops operation (OPEN-B disabled)	Stops operation (OPEN-A/B disabled)
<b>OPENING</b>	No effect	No effect	No effect (OPEN A/B disabled)	No effect (OPEN-A disabled)	No effect (OPEN B disabled)	No effect (OPEN A/B disabled)
<b>LOCKED</b>	Opens the leaf	Closes the leaf				

**Tab. 3/h**

CONTROLS ALWAYS HELD DOWN						
Logic "C"	OPEN-A (opening)	OPEN-B (closing)	STOP	OPENING SAFETY DEVICES	CLOSING SAFETY DEVICES	OP/CL SAFETY DEVICE
<b>GATE STATUS</b>						
<b>CLOSED</b>	Opens the leaf	No effect (OPEN-A disabled)	No effect (OPEN A/B disabled)	No effect (OPEN A disabled)	No effect	No effect (OPEN A disabled)
<b>OPEN</b>	No effect (OPEN-B disabled)	Closes the leaf		No effect (OPEN A disabled)	No effect (OPEN B disabled)	No effect (OPEN B disabled)
<b>CLOSING</b>	Stops operation	/	Stops operation	No effect	Stops operation (OPEN-B disabled)	Stops operation (OPEN-A/B disabled)
<b>OPENING</b>	/	Stops operation		Stops operation (OPEN-A disabled)	No effect	

- (1) If maintained, it prolongs the pause until disabled by the command (timer function)
  - (2) If a new pulse occurs within 2 seconds after reversing, it immediately stops operation.
  - (3) During the partial opening cycle, an OPEN A pulse causes total opening.
- NB.: Effects on other active pulse inputs in brackets.

13. Prewired Enclosure

The 455D board is supplied in an enclosure that integrates a number of functions: Power ON-OFF switch and accessory power outlet, loop detector connectors, operator's capacitors large terminal strip to connect AC power.

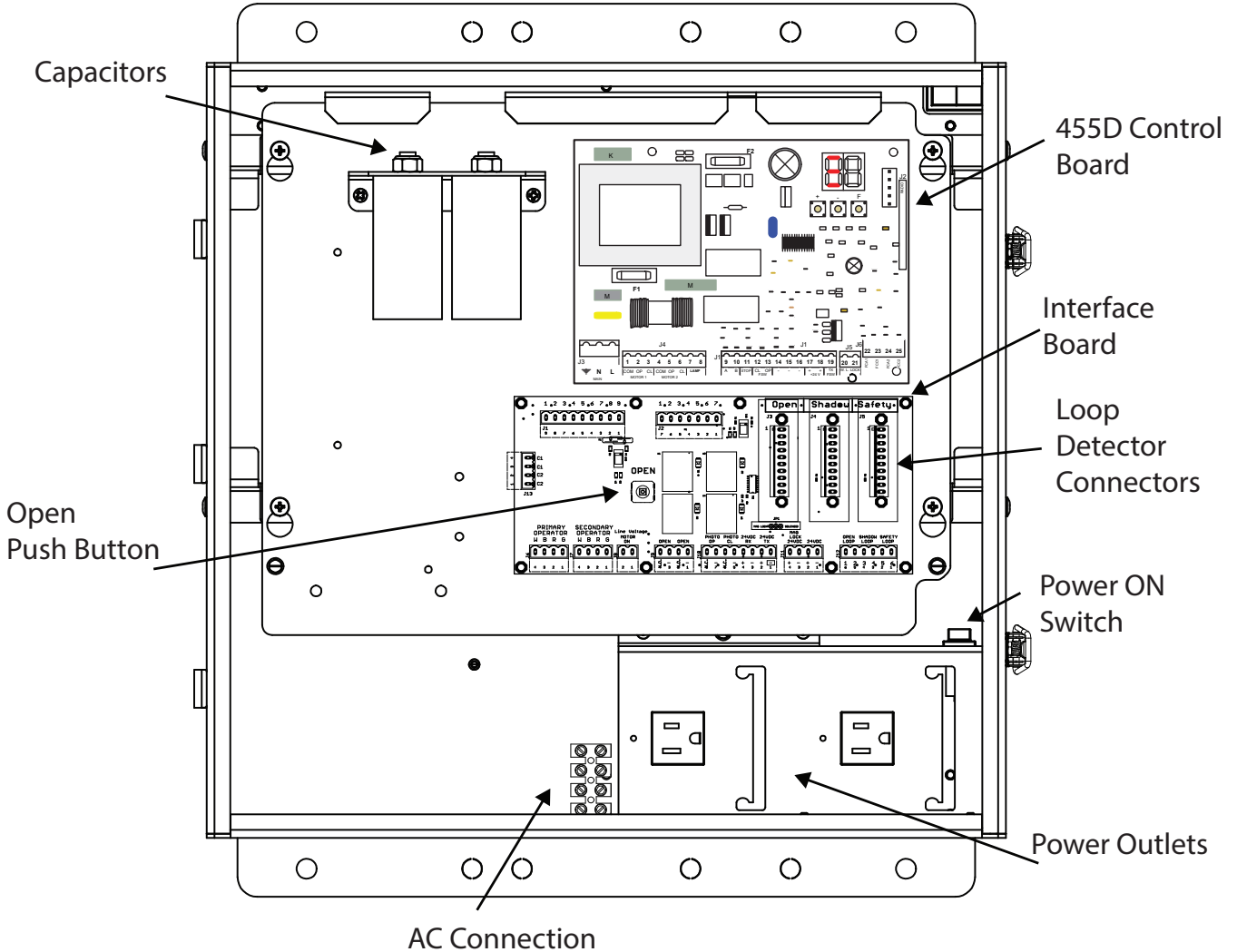

AC Power Wiring Guidelines

1. Check local wiring codes in all cases and follow all local building codes. Wiring and hookup should be performed by qualified electricians/installers only.
2. AC power should be supplied from a circuit breaker panel and must have its own dedicated circuit breaker. This supply must include a green ground conductor.
3. Properly ground the gate operator to minimize or prevent damage from power surges and/or lightning. Use a grounding rod if necessary. A surge suppressor is recommended for additional protection.

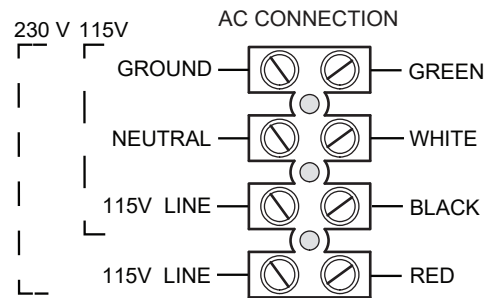

**Monitored safety connections**

The prewired enclosure comes with a dedicated terminal block for the connection of safety photocells that can be monitored by the control board for presence and correct operation. See below for examples of connections.

**IMPORTANT:** The operator requires the connection of the closing safety photocell to work.

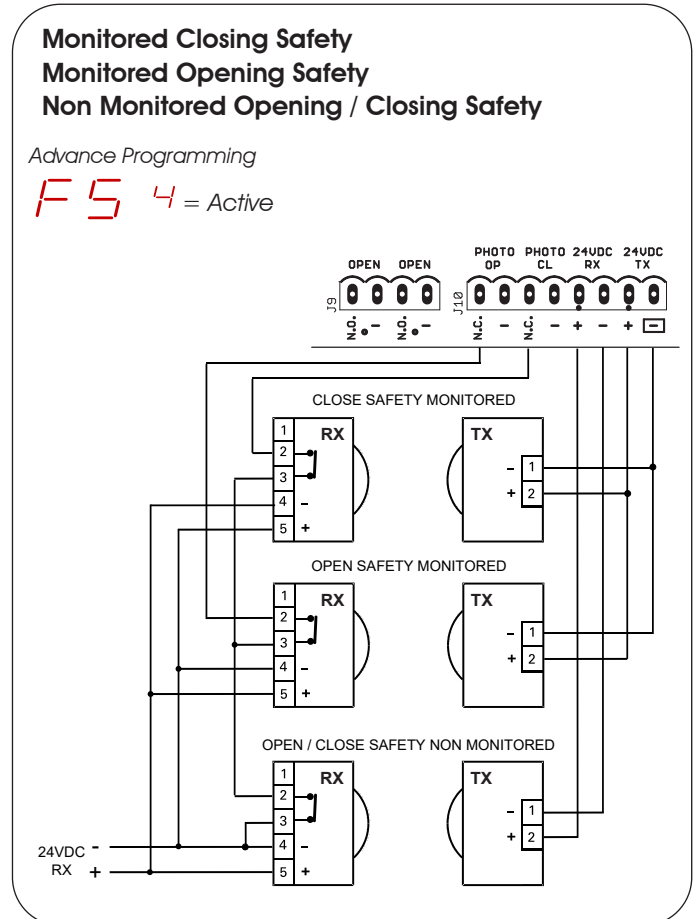
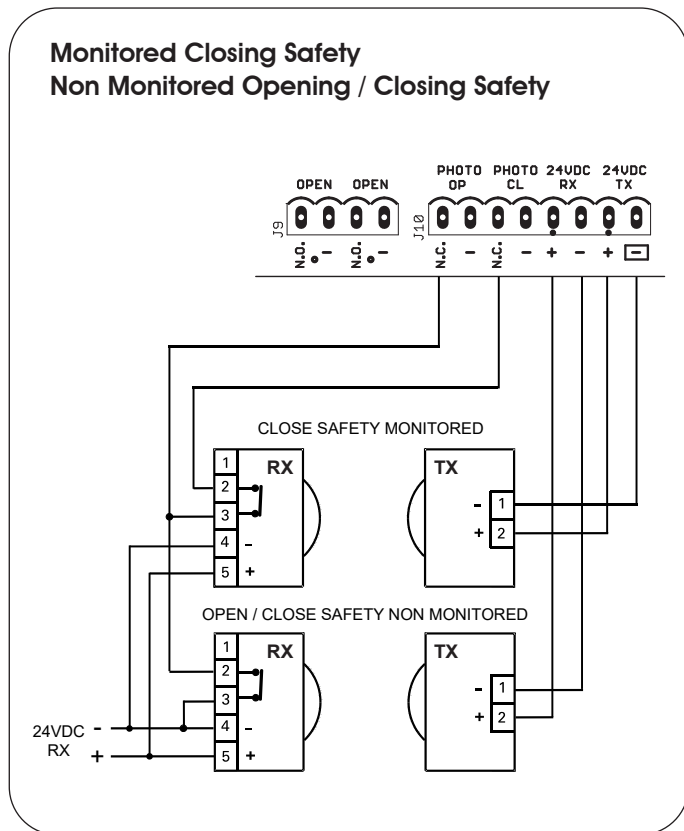
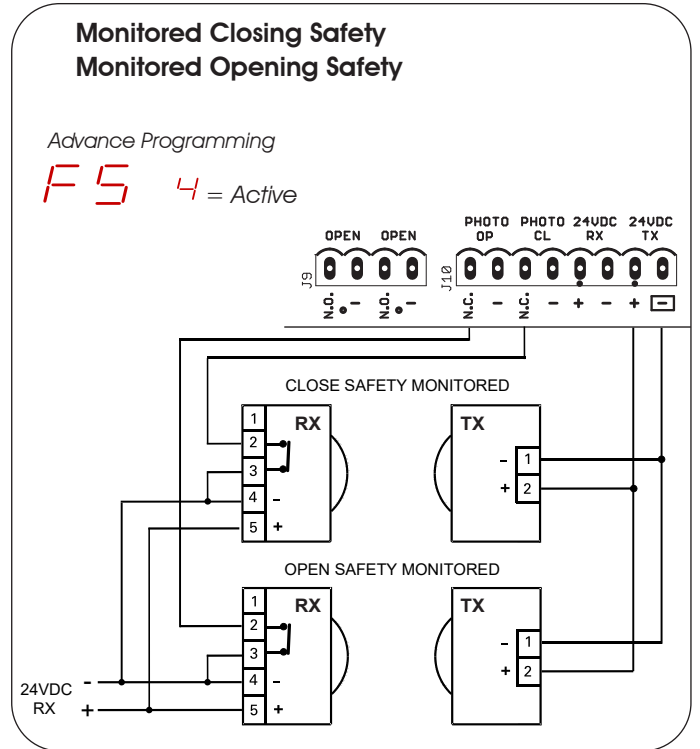
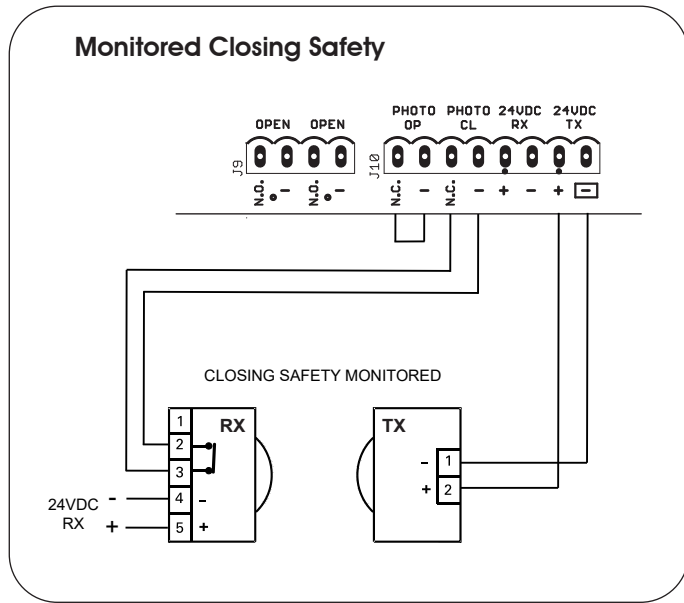

### Additional Monitored Opening Safety

Connect the photocell directly to the 455D board STP input as shown below.

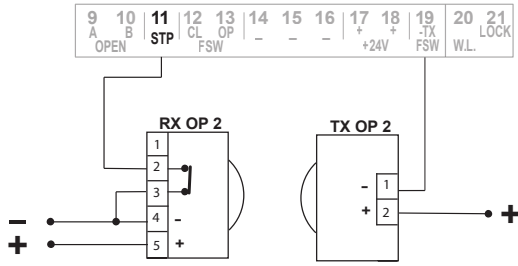

Advance Programming

OP 4 = Active

NOTE: If present remove the jumper from Pin 11

### Maglock or Solenoid connection

The prewired enclosure comes with a dedicated terminal block for the connection of a Maglock or a DC Solenoid. See the diagram below for the wiring. Set the jumper JP1 according with the device used.

Rating: 24VDC - 500 mA.

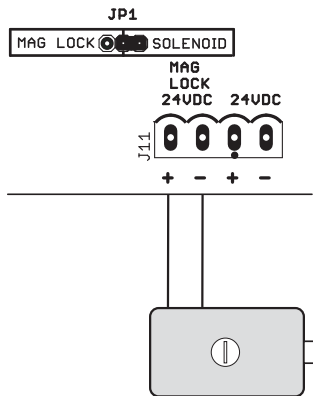
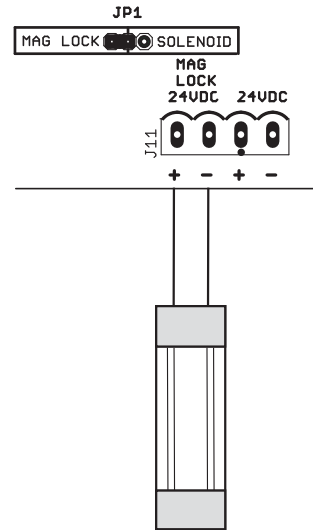

### Loops connection

The prewired enclosure comes with dedicated connectors for 10 pin plug in loop detectors and a terminal block for the wiring of the safety loops. See the diagram below.

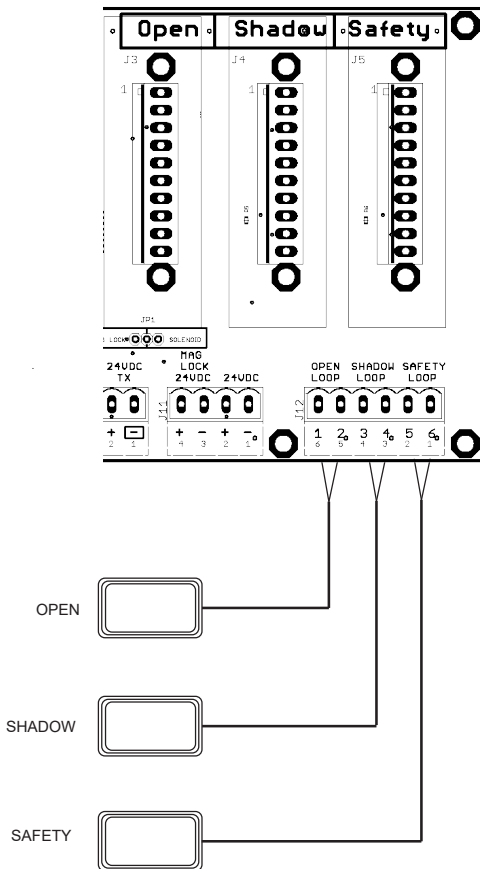

This page is intentionally left blank

Hydraulic drive unit

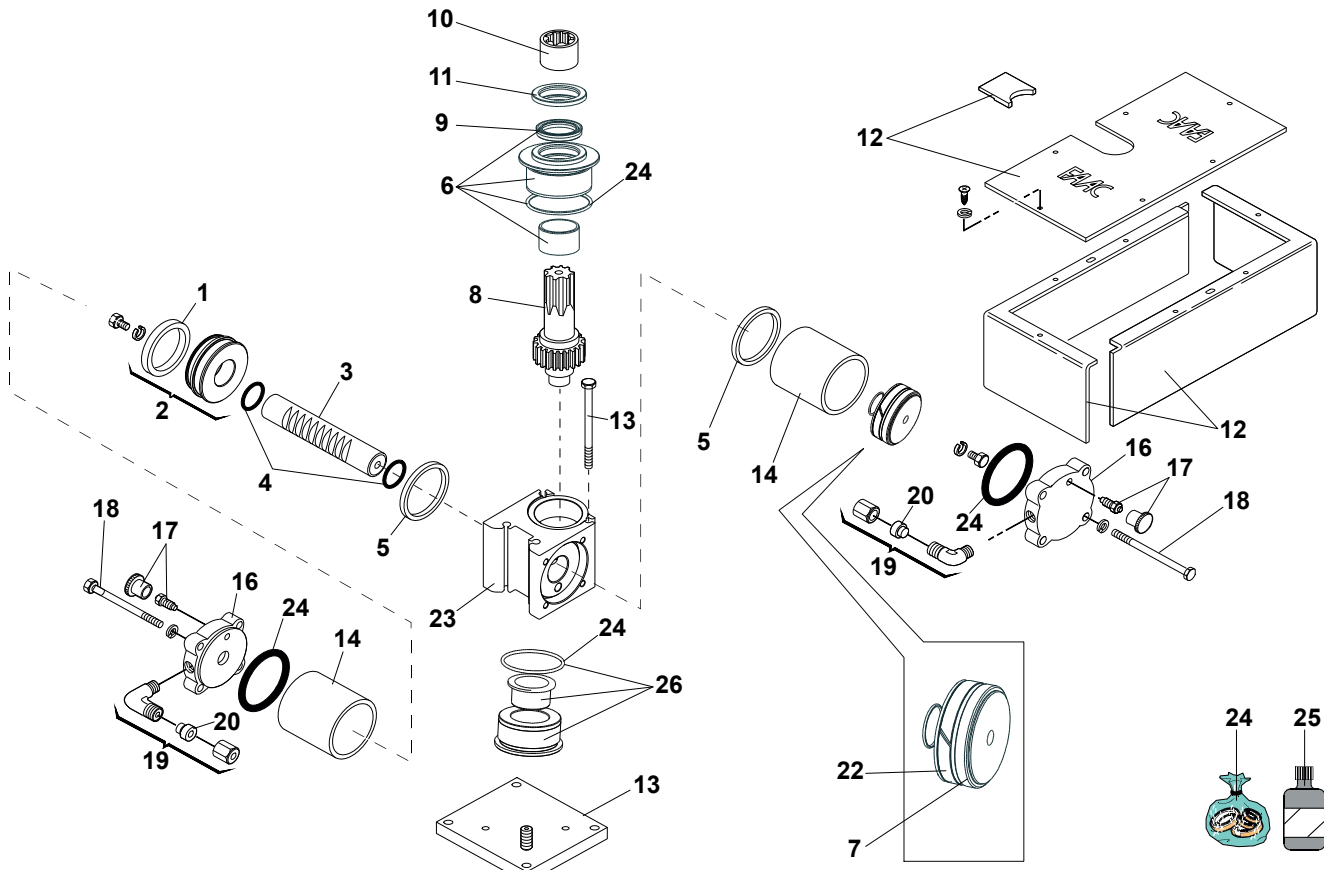

Part	Part Number	Description
1	7092025	Piston Seal
2	390112	Piston Group
3	7193055	100 Degree Rack
4	7090380025	O-Ring 29.82 x 2.62 mm
5	7099195	Cylinder Gasket
6	63003323	Bushings Group
7	7092025	Piston Seal
8	7192465	Pinion Shaft
9	7095075	Top Seal
10	7309095	Splined Joint Collar
11	7093225	Dust Cover
12	63003325	750 Complete Box

Part	Part Number	Description
13	63003324	750 Leveling Plate And Bolt
14	7366245	Cylinder 750 Drive 100 Degree
15	7090170015	O-Ring 66.4 X 1.78mm
16	63003322	750 Operator Flange Group
17	63003308	Bleeding Valve Group
18	7011345	Mounting Bolt (Top)
19	390700	Banjo Bolt Kit
20	7102055	Ferrule Fitting
22	7049195	Piston Seal
23	7161745	Body
24	2171.1	Drive Unit Gasket Kit
25	714019 Qt.1	Oil 1 Quart Bottle FAAC HP

Hydraulic control unit

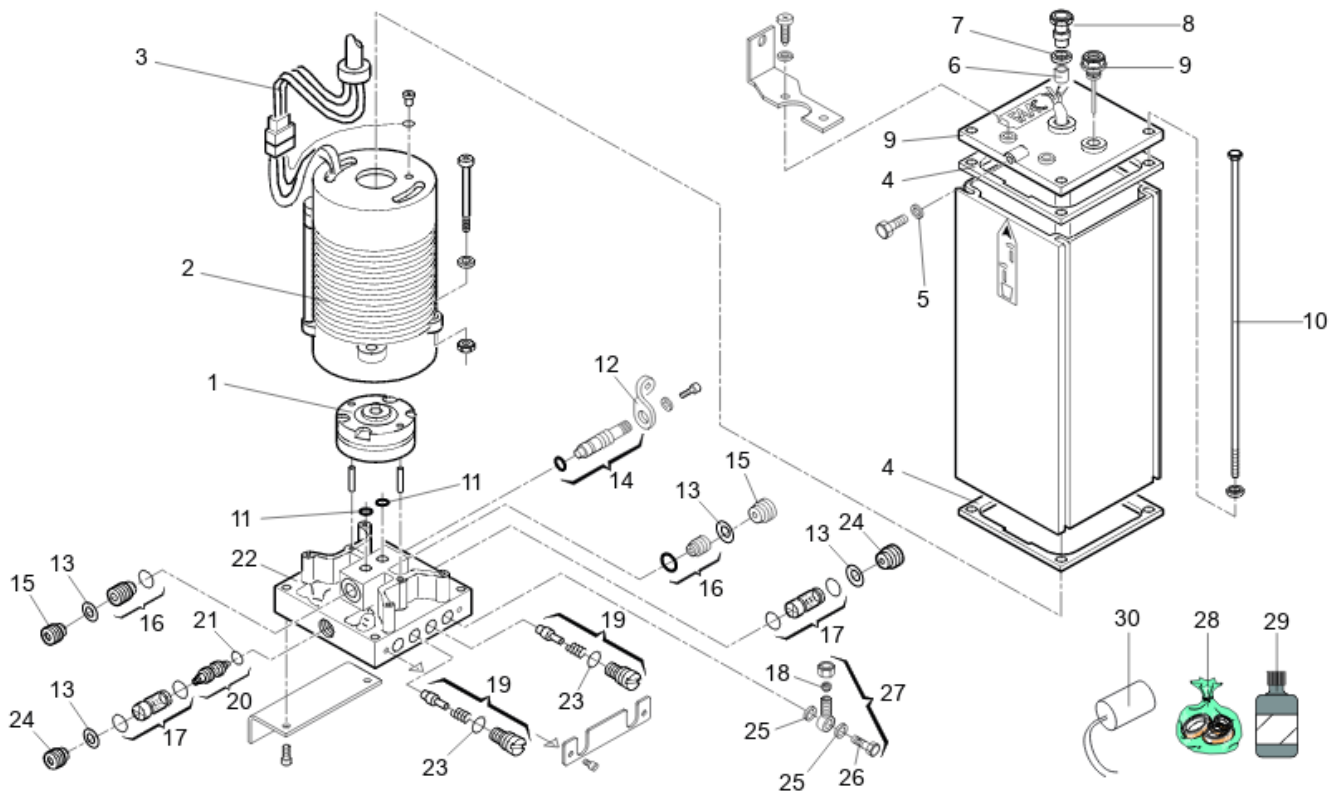

Part	Part Number	Description
1	3204435	Cast Iron Pump Lobe .75 Lt
2	77002025	Motor 115V
3	7514125	Electric Cord UL
4	7099315	Flange Gasket
5	7094065	Copper Washer
6		
7	7109235	Strain Relief Kit
8		
9	7112055	Oil Plug
10	7019145	Tierod (Pack of 5)
11	7090010015	O-Ring 4.48 x 1.78 mm
12	7290155	Manual Release Handle
13	63000577	Washer Cup Spring (30 pc pack)
14	4180225	Manual Release
15	7049135	Valve Retainer
16	4404065	Inlet Valve

Part	Part Number	Description
17	4404085	Lock Valve
18	7102055	Ferrule Fitting
19	4180395	Brass Bypass Valve
20	4180285	Shuttle Piston
21	7090300015	O-Ring 7.66x1.78 mm (20 pcs)
22	63000613	Distribution Flange
23	7090150015	O-Ring 9.25 X 1.78mm
24	7049005	Brass Valve Retainer
25	63003231	Bonded Seal Hydraulic Hoses
26	7110115	Banjo Bolt
27	390700	Banjo Bolt Kit
28	2170.1	Seal Kit Pump Unit
29	714019 QT.1	Oil 1 Quart Bottle FAAC HP
30	2705	Capacitor 115V 25uf



## LIMITED WARRANTY

FAAC International, Inc. ("Seller") warrants the first Purchaser of the product to be free from defects in material and workmanship for a specific period as defined by the Warranty disclosure on the website [www.faacusa.com](http://www.faacusa.com). The Warranty Period commences from the date of invoice.

Control Boards, Accessories or Spare Parts factory installed or sold with any of the products above carry the same warranty period as the product they are sold with, excluding batteries that carry a maximum 2 year warranty.

Products repaired under warranty carry the remainder of the original warranty period. For products repaired outside of warranty, the Seller warrants that all parts used for the repair will be free from defects in materials and workmanship for a period of ninety (90) days.

Defective products must be returned to Seller, freight prepaid by Purchaser, within the warranty period. A Return Material Authorization Number (RMA) must be obtained before product is returned. Items returned will be repaired or replaced, at Seller's option, upon an examination which discloses to the satisfaction of the Seller that the item is defective. The Seller will return the warranted item freight prepaid.

This limited Warranty covers the product under the normal use and service for which it was intended, provided it has been properly installed and operated. Seller's obligations under this warranty shall be limited to the repair or exchange of any part. This warranty shall not apply to products or parts thereof which have been repaired or altered, without Seller's written consent, outside of Seller's workshop or altered in any way so as, in the judgment of Seller, to affect adversely the stability or reliability of the product(s) or has been subject of misuse, negligence, or accident, or has not been operated in accordance with the product's instructions or has been operated under conditions more severe than, or otherwise exceeding, those set forth in the specifications for such product(s).

When the warranty service involves the exchange of an operator or part, the item the Seller replaces becomes its property and the replacement becomes Purchaser's property. The Purchaser represents that all removed items are genuine and unaltered. The replacement may not be new but will be in good working order and at least functionally equivalent to the item replaced. The replacement assumes the warranty service status of the replaced item.

The products are not warranted to meet the specific requirements, if any, of safety codes of any particular state, municipality, or other jurisdiction, and the Seller doesn't assume any risk or liability whatsoever resulting from the use thereof, whether used singly or in combination with other machines or apparatus.

The Seller does not assume nor authorizes any person to assume for them any other liability in connection with the sale or use of the products of beyond that extended herein.

The warranty hereinabove set forth shall not be deemed to cover maintenance parts, including, but not limited to hydraulic oil, motor brushes, or the like. No agreement to replace or repair shall constitute an admission by the Seller of any legal responsibility to effect such replacement to make such repair, or otherwise.

All products sold by the Seller are subject to design and/or appearance modifications, which are production standards at the time of shipment. The Seller may, but shall not be required to, modify or update products shipped prior to a current production standard.

THIS WARRANTY IS EXPRESSLY IN LIEU OF ALL OTHER WARRANTIES EXPRESSED OR IMPLIED INCLUDING THE WARRANTIES OF MERCHANTABILITY AND FITNESS FOR USE. THIS WARRANTY SHALL NOT APPLY TO PRODUCTS OR ANY PART THEREOF WHICH HAVE BEEN SUBJECT TO ACCIDENT, NEGLIGENCE, ALTERATION, ABUSE, OR MISUSE OR IF DAMAGE WAS DUE TO IMPROPER INSTALLATION OR USE OF IMPROPER POWER SOURCE, OR IF DAMAGE WAS CAUSED BY FIRE, FLOOD, LIGHTNING, ELECTRICAL POWER SURGE, EXPLOSION, WIND STORM, HAIL, AIRCRAFT OR VEHICLES, VANDALISM, RIOT OR CIVIL COMMOTION, OR ACTS OF GOD.

The Seller shall not be liable for any loss or damage whatsoever resulting, directly or indirectly, from the use or loss of use of the product(s). Without limiting the foregoing, this exclusion from liability embraces a Purchaser's expenses for downtime or for making up downtime, lost profit, damages for which the Purchaser may be liable to other persons, damage to property, and injury to or death of any persons.

This limited warranty extends only to wholesale customers who buy directly through the Seller's normal distribution channels. The Seller does not warrant its products to end consumers. Consumers must inquire from their selling dealer as to the nature and extent of that dealer's warranty, if any.

THE LIMITED WARRANTY OFFERED HEREIN IS THE SOLE AND EXCLUSIVE REMEDY AVAILABLE TO THE PURCHASER. CORRECTION OF DEFECTS, IN THE MANNER AND FOR THE PERIOD OF TIME DESCRIBED HEREIN, SHALL CONSTITUTE THE COMPLETE FULFILLMENT OF ALL LIABILITIES OF SELLER TO THE PURCHASER WITH RESPECT TO THE COVERED PRODUCT, AND SHALL CONSTITUTE FULL SATISFACTION OF ALL CLAIMS, WHETHER BASED ON CONTRACT, NEGLIGENCE, STRICT LIABILITY OR OTHERWISE. IN NO EVENT SHALL SELLER BE LIABLE FOR ANY LOSS OF PROFITS OR ANY INDIRECT, CONSEQUENTIAL, INCIDENTAL, SPECIAL OR PUNITIVE DAMAGES ARISING OUT OF SELLER'S BREACH OF THIS LIMITED WARRANTY, OR ARISING OUT OF THE CUSTOMER'S INABILITY TO USE THE COVERED PRODUCT, EVEN IF SELLER HAS BEEN ADVISED OF THE POSSIBILITY OF SUCH DAMAGES.

Some states do not allow the exclusion or limitation of incidental or consequential damages, so the above limitation may not apply to a particular Purchaser. This Limited Warranty gives the Purchaser specific legal rights. The Purchaser may also have other rights, which vary from state to state.

