

6500 VEHICULAR SWING GATE OPERATOR



Easy access design, low maintenance & quiet operation

- Split housing allows easy access without having to remove the gate arm
- Easy to adjust electronic magnetic limits eliminate old style mechanical switches that can wear out, break or fail
- Unique breakaway hub design prevents gear box damage if the gate is struck
- Steel frame for strength and durability
- Easy to use manual release system
- 5-Year limited warranty

RESIDENTIAL • COMMERCIAL • INDUSTRIAL

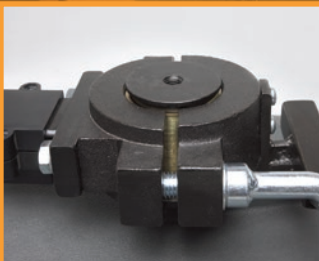

Breakaway Hub

unique design prevents gear box damage if the gate is struck



Steel Frame

for strength and durability



Gate Tracker™

record users access



Easily Adjustable

electronic magnetic limits

ACCESS CONTROL SOLUTIONS



6500 VEHICULAR SWING GATE OPERATOR

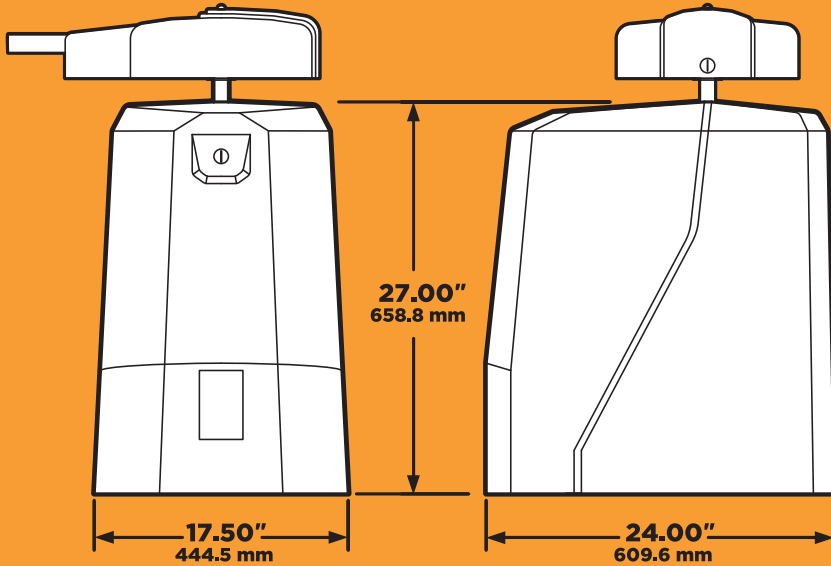

6500	1/2 HP	1 HP
CLASS OF OPERATION	I, II, III, IV	I, II, III, IV
MAX GATE LENGTH*	18 ft (5.5 m)	22 ft (6.7 m)
MAX GATE WEIGHT*	700 lb (318 kg)	800 lb (362 kg)
MOTOR	1/2 HP Continuous Duty AC Motor	1 HP Continuous Duty AC Motor
INPUT	115 VAC, 60 Hz, 5.4A 208 VAC, 60 Hz, 2.8A** 230 VAC, 60 Hz, 2.7A** 460 VAC, 60 Hz, 1.4A**	115 VAC, 60 Hz, 9.7A 208 VAC, 60 Hz, 5.0A** 230 VAC, 60 Hz, 4.9A** 460 VAC, 60 Hz, 2.5A**
OPTIONS	Heater Kit Uphill Arm Pivot Kit	Heater Kit Uphill Arm Pivot Kit

* Assumes gate to be in good condition and swinging in a level plane.

** These operators use a step-down transformer to achieve 115 VAC operating voltage.

TECHNICAL FEATURES

MECHANICAL

Primary reduction is provided by a pulley / belt driving a 60:1 worm gear reduction system running in a continuous oil bath

The 6500 rotates the gate 90° in approximately 12-14 seconds

Operator mechanics are mounted on a steel frame plated for corrosion resistance

Two-piece articulating arm mechanical slow-start / slow-stop function

Mounting: operator requires a concrete mounting pad

Keyed access is provided to release arm for manual gate operation in the event of a power outage

Split polypropylene housing simplifies installation and maintenance.

Unique breakaway hub helps to protect the gear box if the gate is rammed

GATE TRACKER™

Reporting output provides operator data to a DKS 1833, 1835, 1837 or 1838 access control system (requires 2358 expansion board)

ELECTRICAL

Adjustable electronic magnetic limits

Auto-close timer (1-23 seconds)

Gate overlap feature for bi-parting (dual) gate operation

Simple connection for secondary operator in bi-parting gate systems

Built-in On / Off switch

Built-in alarm reset switch

Selectable shadow / reverse loop function

Magnetic lock power

Ports for plug-in open and reverse loop detectors (DKS plug-in detectors only)

Three 115 VAC convenience outlets for accessory transformers

MISCELLANEOUS

Environmental: 10°F to 115°F (-12°C to 62°C)

Thermostatically controlled heater kit recommended for colder environments

Shipping weight approximately 175-225 lb (79-102 kg) depending on model and options selected

Operator requires monitored Type B1 and/or Type B2 entrapment protection devices



Conforms to ANSI/CAN/UL 325:2017 Ed. 7
Certified to CSA C22.2 #257

DoorKing® Inc.

Access Control Solutions since 1948



120 S. Glasgow Avenue,
Inglewood, California 90301 U.S.A.
Tel: 310-645-0023 FAX: 310-641-1586
www.doorking.com

© 2020 All Rights Reserved.
Product specifications may
change without notice. Rev. 6/20



MEMBER:



DISTRIBUTED BY:



Power Door Products

(914) 698-5083

www.PowerDoorProducts.com