

# powermaster

SG

**Slide Gate Operator for use in Commercial and Industrial Applications.**

SG

## **STANDARD FEATURES**

- SOLID STATE CONTROL BOARD WITH DIAGNOSTIC LEDs
- TIMER TO CLOSE
- SELF ADJUSTING MAXIMUM RUN TIMER
- EASY LEFT/RIGHT CHANGEOVER
- ONBOARD, 3-BUTTON CONTROL STATION
- HEAVY DUTY STEEL FRAME WITH POLYETHYLENE RUST & DENT PROOF COVER



*Complete selection of control stations  
& accessories are available.*

All gate operators must have contact and non-contact sensing system installed for operator to work properly and safely.



Power Door Products

(914) 698-5083

[www.PowerDoorProducts.com](http://www.PowerDoorProducts.com)

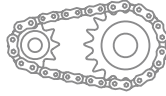

## SPECIFICATIONS & FEATURES

**AVAILABLE HORSE POWER:** 1/2 HP - 2 HP

**POWER OPTIONS:** 115/230V, 1 PHASE; OR 230/460V, 3 PHASE

CLASS II LOW VOLTAGE CONTROL CIRCUIT

**GATE CAPACITY:** 1500 LBS, 50 FT WIDE, UP TO 30 CYCLES PER HOUR

**TRAVEL SPEED:** 9 INCHES PER SECOND

HEAVY DUTY #11 GA. STEEL FRAME

40:1 GEAR REDUCER IN OIL BATH ASSURES SMOOTH AND QUIET OPERATION

HARD SHELL, BAKED ON, WEATHER RESISTANT POWDER COATING

POST OR PAD-MOUNTABLE

PADLOCKABLE DRIVE DISCONNECT WITH BRASS SLIDE FOR MANUAL OPERATION IN CASE OF POWER FAILURE

UL 325 LISTED FOR USE IN CLASS I THROUGH IV APPLICATIONS

**SHIPPING WEIGHT:** APPROX. 236 LBS (WITH PLATFORM)

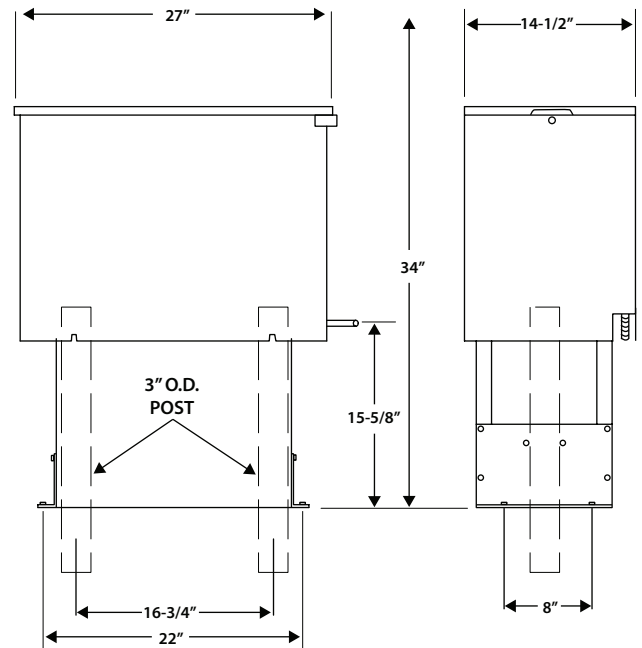

## OPTIONAL EQUIPMENT

- ADDITIONAL SAFETY EDGE (CONTACT SAFETY SENSOR)
- ADDITIONAL PHOTO CELL (NON-CONTACT SAFETY SENSOR)
- PLUG-IN LOOP DETECTORS
- WARNING EQUIPMENT (HORNS, LIGHTS)
- GEAR BOX HEATER FOR COLD CLIMATES
- THERMOSTATICALLY CONTROLLED COOLING FAN FOR HOT CLIMATES
- TORQUE LIMITING CLUTCH
- STEEL COVER IN LIEU OF POLYETHYLENE COVER

## CAUTION

A moving gate can cause serious injury or death! Carefully read and follow all safety instructions, precautions, and guidelines when installing and using this product. Motorized gates are for vehicles only. Pedestrians must use a separate entrance. **NO ONE SHOULD CROSS THE PATH OF A MOVING GATE!** Proper reversing devices must be installed on gates to avoid all hazards, pinch points and entrapment. Eliminate all hazards, pinch points and entrapment areas. Warning signs must be permanently installed and visible to traffic and pedestrians. Do not mount operating devices accessible through gates or between a gate and wall. Never allow children to lay in the path of a gate. Never allow children to operate or play with the gate controls. Follow UL 325 and ASTM F220-02 standards. Do not install this product unless all hazards, pinch points and entrapment points are protected.

