

6524 VEHICULAR AC/DC SWING GATE OPERATOR



DC swing gate operator, battery back-up & solar power

- 115/230 VAC (switch selectable) input power or 24 VDC solar power
- 1/2 HP quadra drive heavy-duty DC motor
- Split housing allows easy access without having to remove the gate arm
- Easy to adjust electronic magnetic limits eliminate old style mechanical switches that can wear out, break or fail
- Heavy-duty steel frame
- 0.0 Amp SBPD circuit (solar power only)
- Solar power ready
- 5-Year limited warranty

RESIDENTIAL • COMMERCIAL



Easy to Operate
manual release



Steel Frame
for strength and durability



Gate Tracker™
record users access

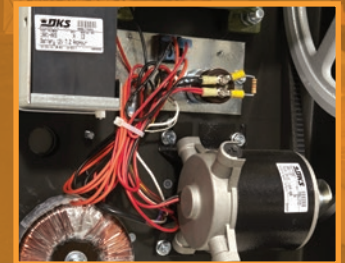

DC Motor & Battery Backup
for continued gate operation if
AC power is lost

ACCESS CONTROL SOLUTIONS



6524 VEHICULAR SWING GATE OPERATOR

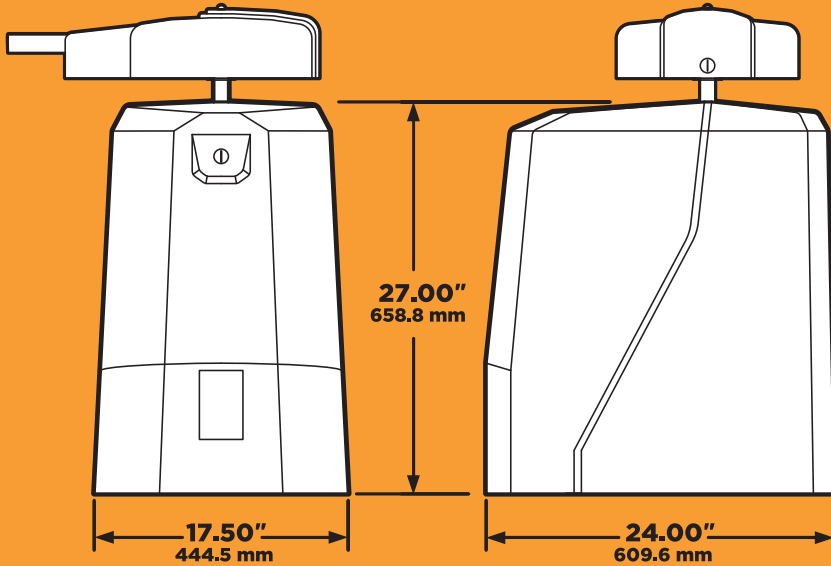

	6524-380 (AC power)	6524-381 (solar power input)
CLASS OF OPERATION	I, II, III, IV	I, II, III, IV
MAX GATE LENGTH*	16 ft (4.87 m)	16 ft (4.87 m)
MAX GATE WEIGHT*	800 lb (363 kg)	800 lb (363 kg)
MOTOR	1/2 HP Quadra Drive DC Motor	1/2 HP Quadra Drive DC Motor
INPUT	115 / 230 VAC 1.8 A / 0.9 A	24 VDC 8.5 A
MAXIMUM CYCLES	Continuous with AC source power 40 with 7.2 Ah backup battery power ^{1,2} 150 with 18 Ah backup battery power ^{1,2}	150+ ^{1,2} with DK solar kit, unknown with systems / batteries provided by others

1 Assumes gate swings in a level arc, in good condition with properly adjusted hardware.

2 Assumes a 16 ft gate weighing 800 lb. Other external factors (temperature, charge state of batteries, gate weight, gate length, etc.) will affect the performance of the Gate Operator and may reduce the number of cycles shown.

TECHNICAL FEATURES

MECHANICAL

Primary reduction is provided by a pulley / belt driving a 60:1 worm gear reduction system running in a continuous oil bath

The 6524 rotates the gate 90° in approximately 12-14 seconds

Operator mechanics are mounted on a steel frame plated for corrosion resistance

Two-piece articulating arm mechanical slow-start / slow-stop function

Mounting: operator requires a concrete mounting pad

Keyed access is provided to release arm for manual gate operation in the event of a power outage

Split polypropylene housing simplifies installation and maintenance, no need to remove the gate arm

Unique breakaway hub helps to protect the gear box if the gate is rammed

GATE TRACKER™

Reporting output provides operator data to a DKS 1833, 1835, 1837 or 1838 access control system (requires 2358 expansion board)

OPTIONS

18 Ah batteries (operator includes two (2) 7.5 Ah SLA batteries)

Solar kit (Includes two 18 Ah batteries and 10 watt, 24 VDC solar panel)

ELECTRICAL

Easy adjustable electronic magnetic limit switches

Auto-close timer 1-30 seconds

Gate overlap feature for dual (bi-parting) gate operation

Selectable shadow / reverse loop function

DC power shut-off switch

Battery protection circuit

Ports for plug-in open and reverse loop detectors.

DKS plug-in detectors only

AC Powered Operator Only

115 VAC convenience outlets

AC power shut-off switch

Magnetic lock power

DC Powered Operator Only

0.0 Amp SBPD^{PatPend} circuit

MISCELLANEOUS

Environmental: 10°F to 115°F (-12°C to 46°C)

Thermostatically controlled heater kit required for operation below freezing temperatures to prevent batteries from freezing. Heater kit can only be used with AC powered operators

Shipping weight approximately 175-225 lb (79-102 kg) depending on model and options selected

Operator requires monitored Type B1 and/or Type B2 entrapment protection devices



Conforms To ANSI/CAN/UL 325:2017 Ed. 7
Certified To CSA C22.2 #247

Intertek

DISTRIBUTED BY:

DoorKing®, Inc.

Access Control Solutions since 1948



120 S. Glasgow Avenue,
Inglewood, California 90301 U.S.A.
Tel: 310-645-0023 FAX: 310-641-1586
www.doorking.com

© 2020 All Rights Reserved.
Product specifications may
change without notice. Rev. 6/20



MEMBER:



Power Door Products

(914) 698-5083

www.PowerDoorProducts.com