

4

3

2

1



Power Door Products

(914) 698-5083

www.PowerDoorProducts.com

*All in GRAY, contact PDP directly.

ITEM NO.	DESCRIPTION	PART NUMBER	QTY.
1	FRAME ONLY	SL-102FM	1
2	GEARBOX	GBX-101	1
3	GEARBOX PULLEY	PLY-25A	1
4	GEARBOX LIMIT SPROCKET	41B12X78	1
5	GEARBOX DRIVE SPROCKET	41B22X78	1
6	1/2 HP BRUSHLESS DC MOTOR	MTR-1500	1
7	1/2 HP BRUSHLESS DC MOTOR BRACKET	MTR-1500B	1
8	1/2 HP AC MOTOR PULLEY	PLY-2	1
9	1/2 HP AC MOTOR BELT	4L-260	1
10	CONTROL BOX ASSEMBLY	CBX-AY101	1
11	CONTROL BOX	CBX-101	1
12	CONTROL BOX COVER	CBC-101	1
13	CONTROL BOX RADIO RECEIVER STRIP	COM-1003	1
14	CONTROL BOX RESET PUSH BUTTON	COM-1004	1
15	CONTROL BOX ALARM BUZZER	COM-1005	1
16	CONTROL BOX DC CONTROL BOARD - 1 HP	BLDC-ULPCB1	1
17	CONTROL BOX BRIDGE RECTIFIER	COM-1006	1
18	CONTROL BOX LINE IN HARNESS	COM-1016	1
19	LIMIT SWITCH BOX ASSEMBLY	LSB-AY101	1
20	LIMIT CHAIN	41NPX18	1
21	LIMIT SPROCKET	41B15X58	1
22	LIMIT SHAFT	LST-100	1
23	LIMIT SHAFT BEARING	BRG-6202B	2
24	LIMIT SWITCH BOX	LBX-101	1
25	LIMIT SWITCH BOX PLATE	LSP-101	1
26	LIMIT SWITCH BOX PLATE SPRING (2 PCS)	SPG-7575	1
27	LIMIT SWITCH	COM-1007	2
28	LIMIT SWITCH PLASTIC NUT	COM-1008	2
29	LIMIT SWITCH WIRE HARNESS	LSH-101	1
30	POWER SUPPLY BOX ASSEMBLY	PSB-AY100	1
31	POWER SUPPLY BOX	PSB-101	1
32	POWER SUPPLY BOX SIDE COVER	PSC-101	1
33	POWER SUPPLY BOX FRONT COVER	PSC-101A	1
34	POWER SUPPLY BOX TRANSFORMER	TFR-480	1
35	POWER SUPPLY BOX 110VAC OUTLET	COM-1001	1
36	POWER SUPPLY BOX ON/OFF POWER SWITCH	COM-1000	2
37	POWER SUPPLY BOARD	EMI-PCB	1
38	POWER SUPPLY WIRE HARNESS	PSH-101	1
39	BATTERY BOX ASSEMBLY	BTY-AY101	1
40	7AH BATTERY	BTY-1270	2
41	BATTERY BOX	BTB-101	1
42	BATTERY BOX COVER	BTC-101	1
43	BATTERY WIRE HARNESS	BTY-H101	1
44	FOOT PEDAL RELEASE ASSEMBLY	FPR-AY100	1
45	FOOT PEDAL RELEASE	FPR-100	1
46	FOOT PEDAL RELEASE KILL SWITCH	COM-1007P	1
47	FOOT PEDAL SPRING	SPG-100FP	1
48	FOOT PEDAL PAD LOCK PLATE	PLP-100FP	1
49	FOOT PEDAL HINGE PIVOT BRACKET	HPB-100FP	1
50	FOOT PEDAL HINGE BRACKET	HBK-100FP	1
51	FOOT PEDAL HINGE SPLIT BRACKET	HSB-100FP	1
52	FOOT PEDAL SQUARE HINGE SHAFT	SHS-100FP	1
53	EXTERIOR PLASTIC COVER	EPC-100FP	1
54	PLASTIC CHAIN IDLER	COM-1017	2
55	CHAIN BRACKET	COM-1009	1
56	CHAIN BOLT	COM-1010-1	1
57	LOOP RACK	LPR-2	1
58	LOOP RACK WIRE HARNESS	LPR-H101	1

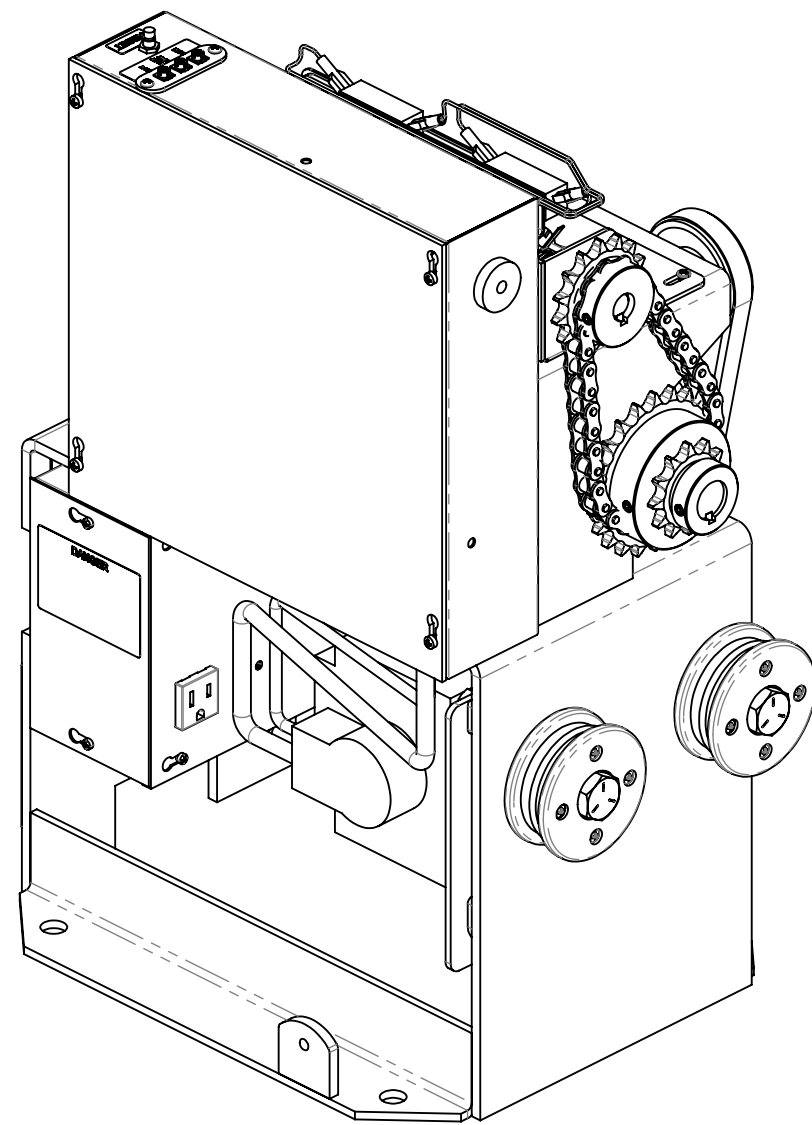
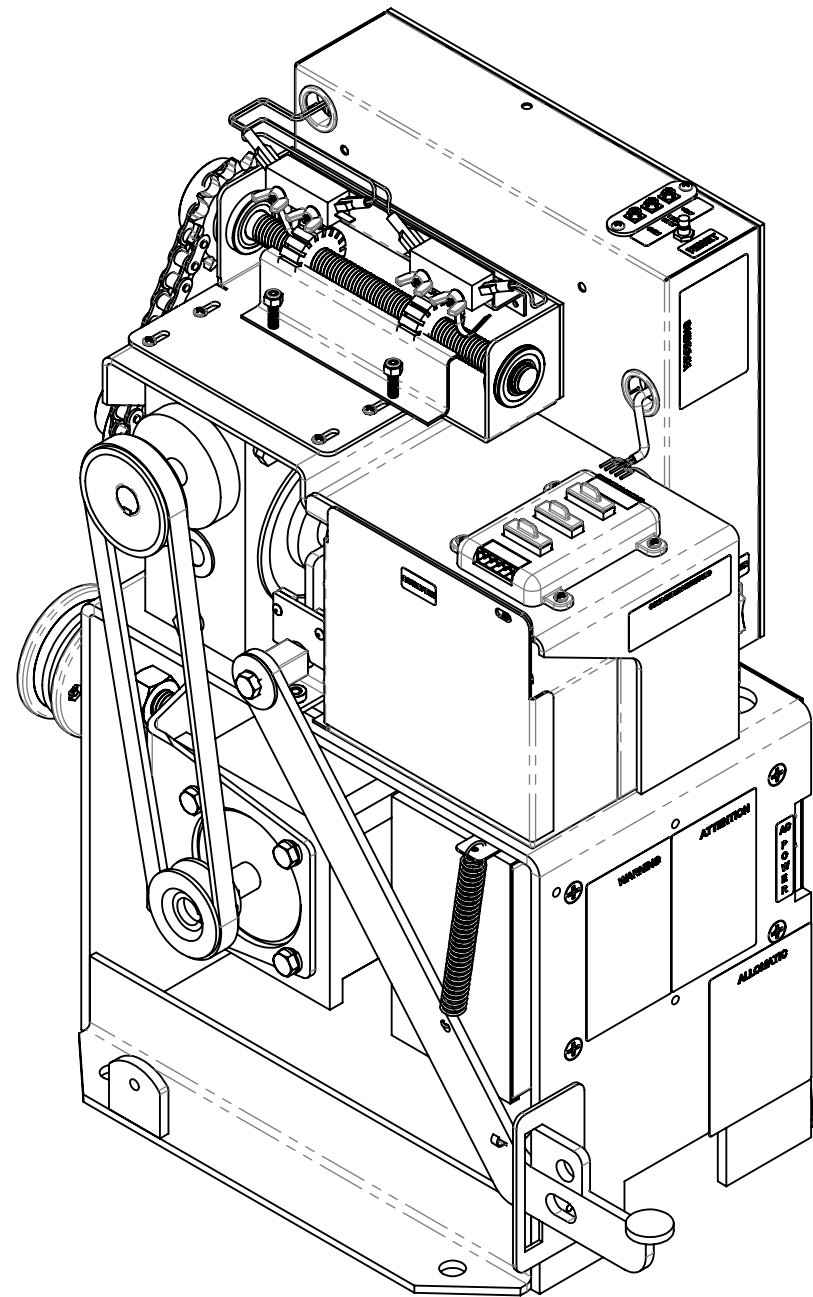
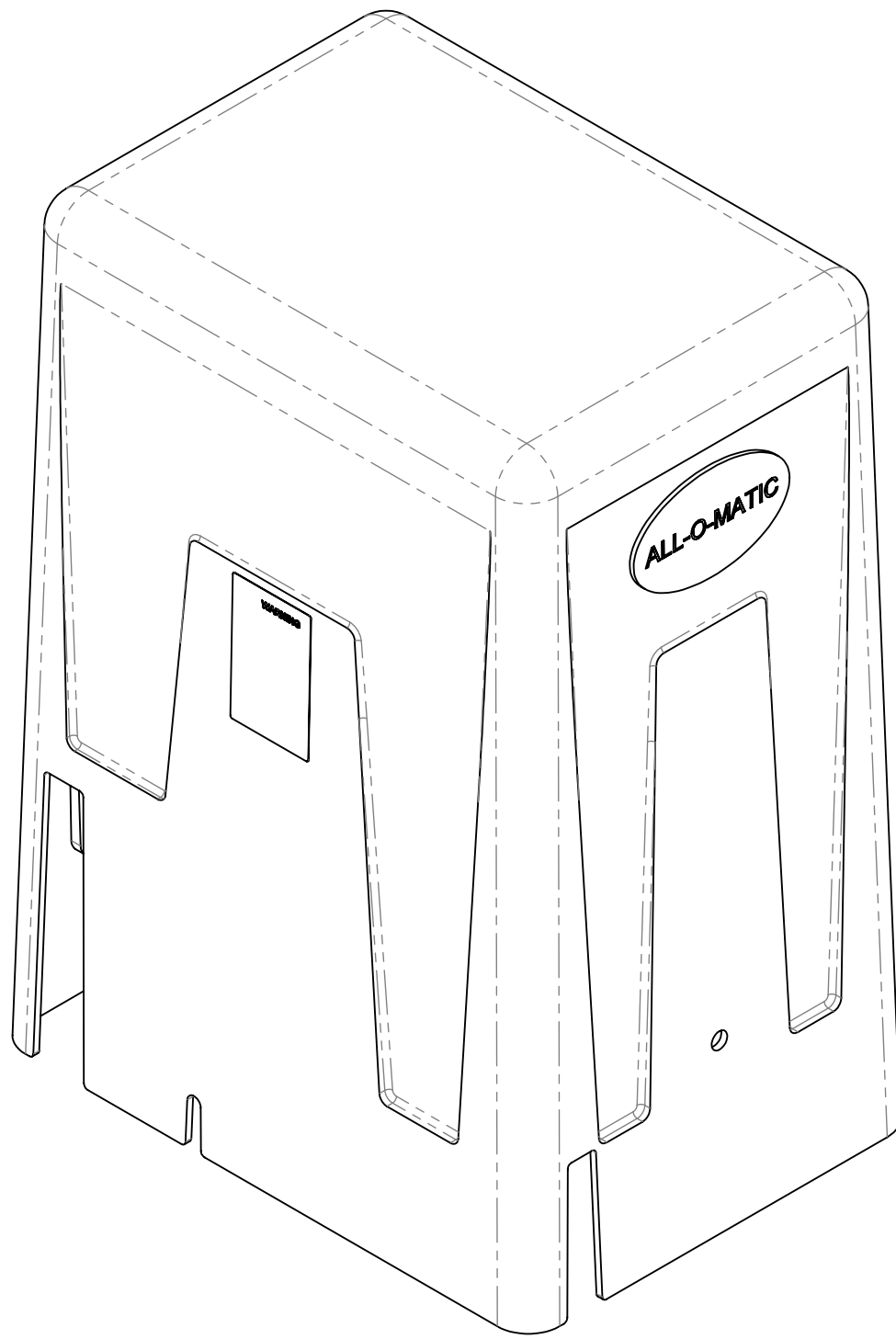

ALL-O-MATIC, Inc.
 7820 Gloria Ave. Phone: (818) 787-1988
 Van Nuys CA, USA 91406
 EMAIL: fortino@allomatic.net

DIMENSIONS ARE IN INCHES
 BREAK SHARP EDGES 10-40
 MACHINED SURFACE FINISH IS
 1.6 MICROMETERS
 DO NOT SCALE DRAWING

THE INFORMATION DISCLOSED HEREIN WAS ORIGINATED BY
 AND IS THE PROPERTY OF ALL-O-MATIC, INC. AND ALL PATENT,
 PROPRIETARY, DESIGN, USE, SALE, MANUFACTURING, AND
 REPRODUCTION RIGHTS THERETO ARE RESERVED BY
 ALL-O-MATIC, INC.

DRAWN BY: S. HUERTA DATE: 09/10/2020 CHECKED BY: X DATE CHECKED: X
 MATERIAL: RAW MAT:

TITLE: **DC SLIDERSL-100FP DC**
 SHEET 1 OF 2 SCALE: 1:4 DRAWING SIZE: C PART#: SL-100FP DC

1	ECO#	ENGINEERING CHANGE ORDER REVISION DESCRIPTION	BY	CKD	DATE

4

3

2

1

4

3

2

1

D

D

C

C

B

B

A

A

POWER SUPPLY BOX ASSEMBLY: PSB-AY100 (30)

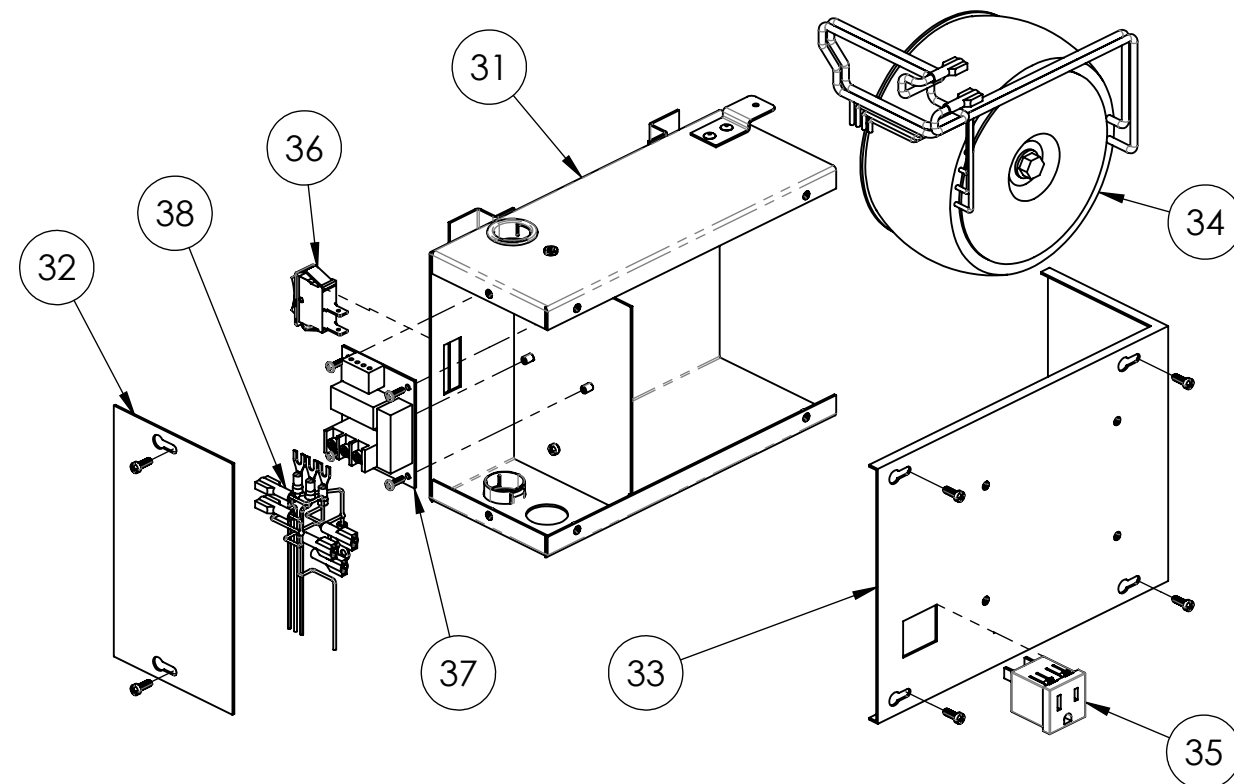

CONTROL BOX ASSEMBLY: CBX-AY101 (10)

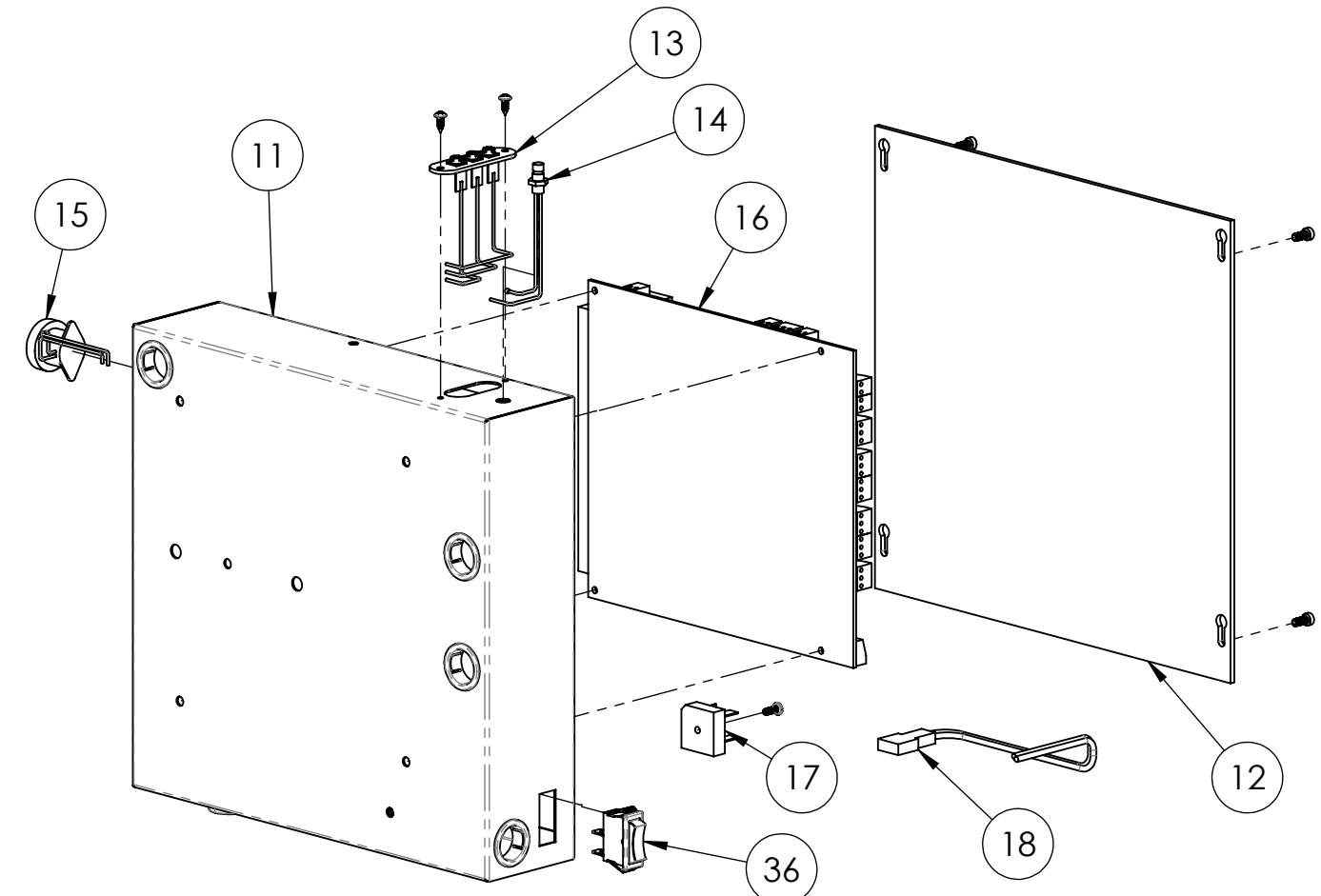

FOOT PEDAL RELEASE ASSEMBLY: FPR-AY100 (44)

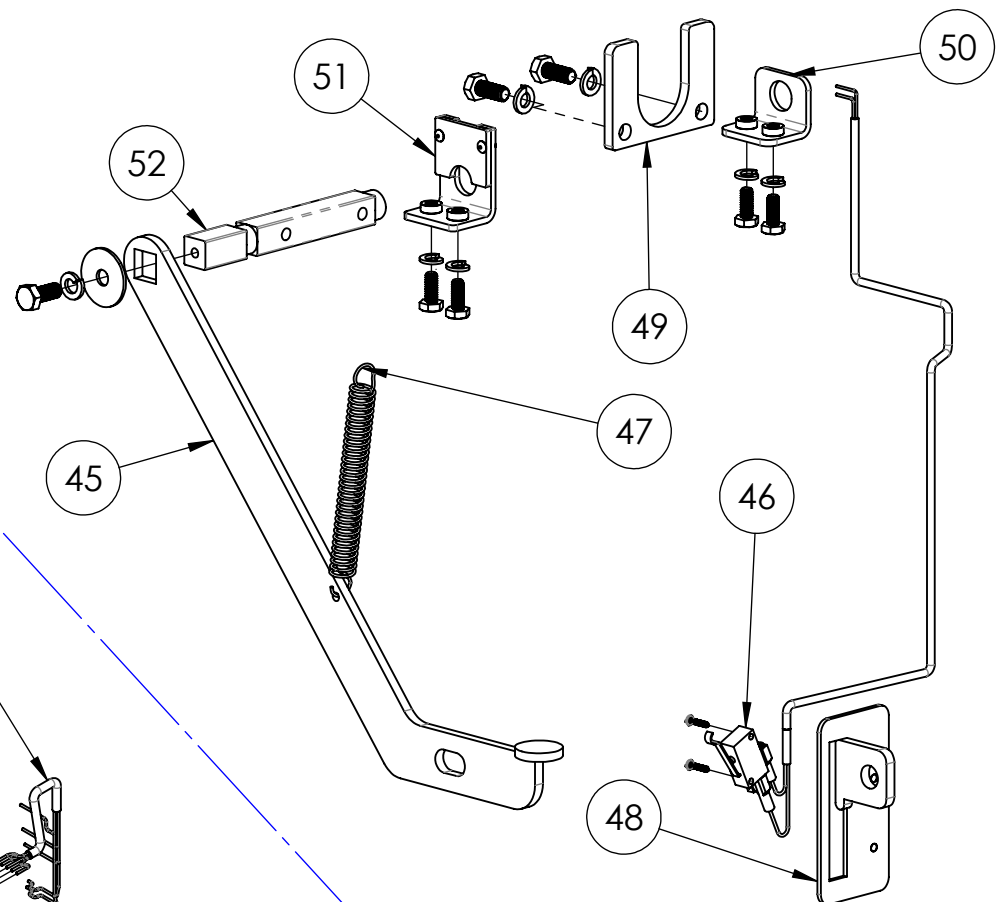

LIMIT SWITCH BOX ASSEMBLY: LSB-AY101 (19)

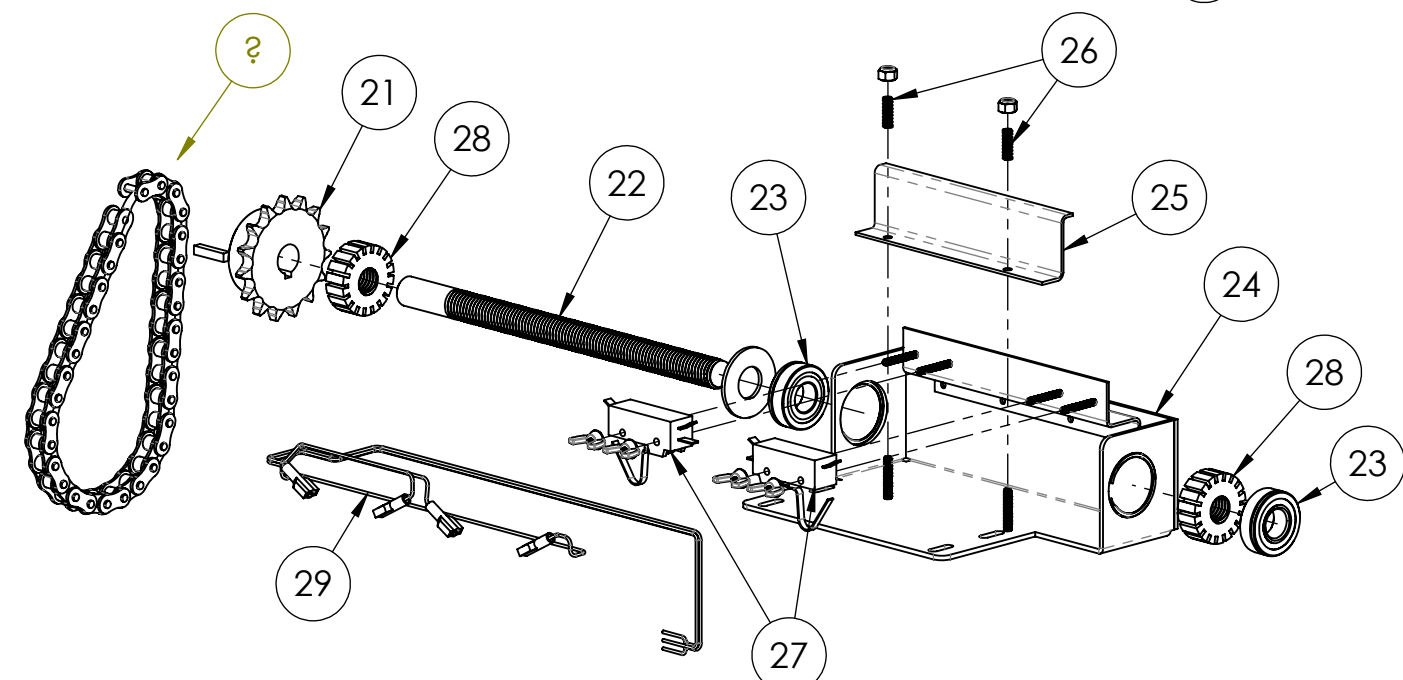

BATTERY BOX ASSEMBLY: BTY-AY101 (39)

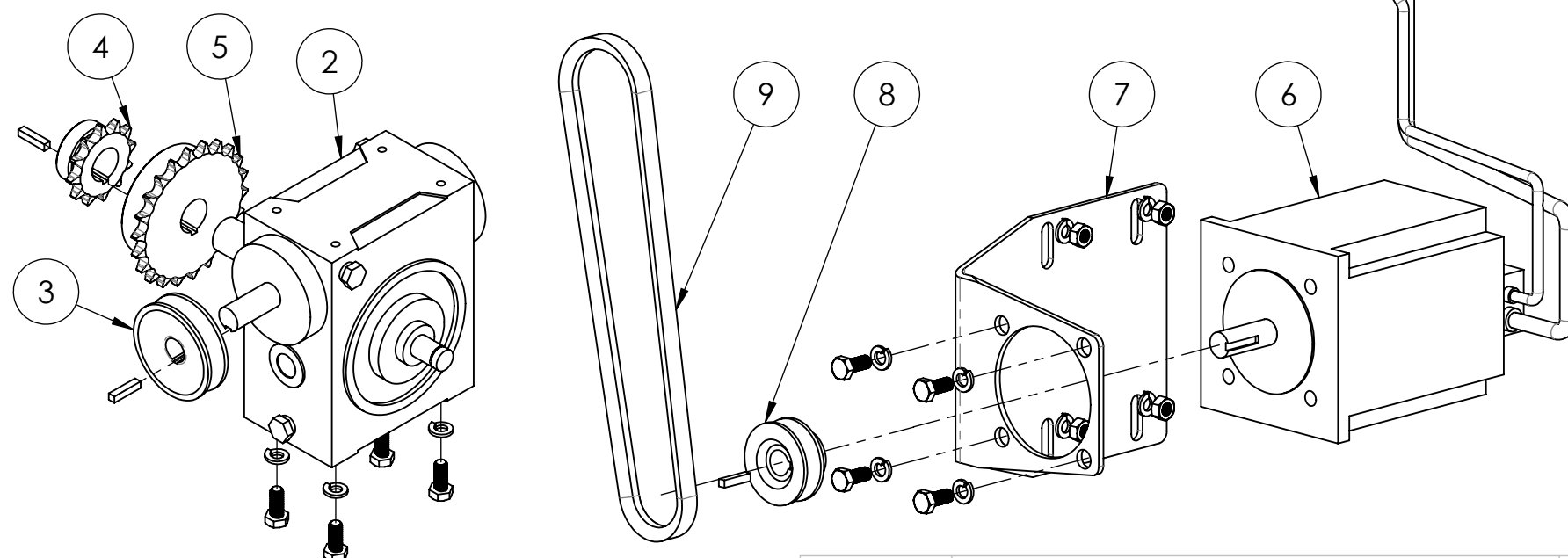
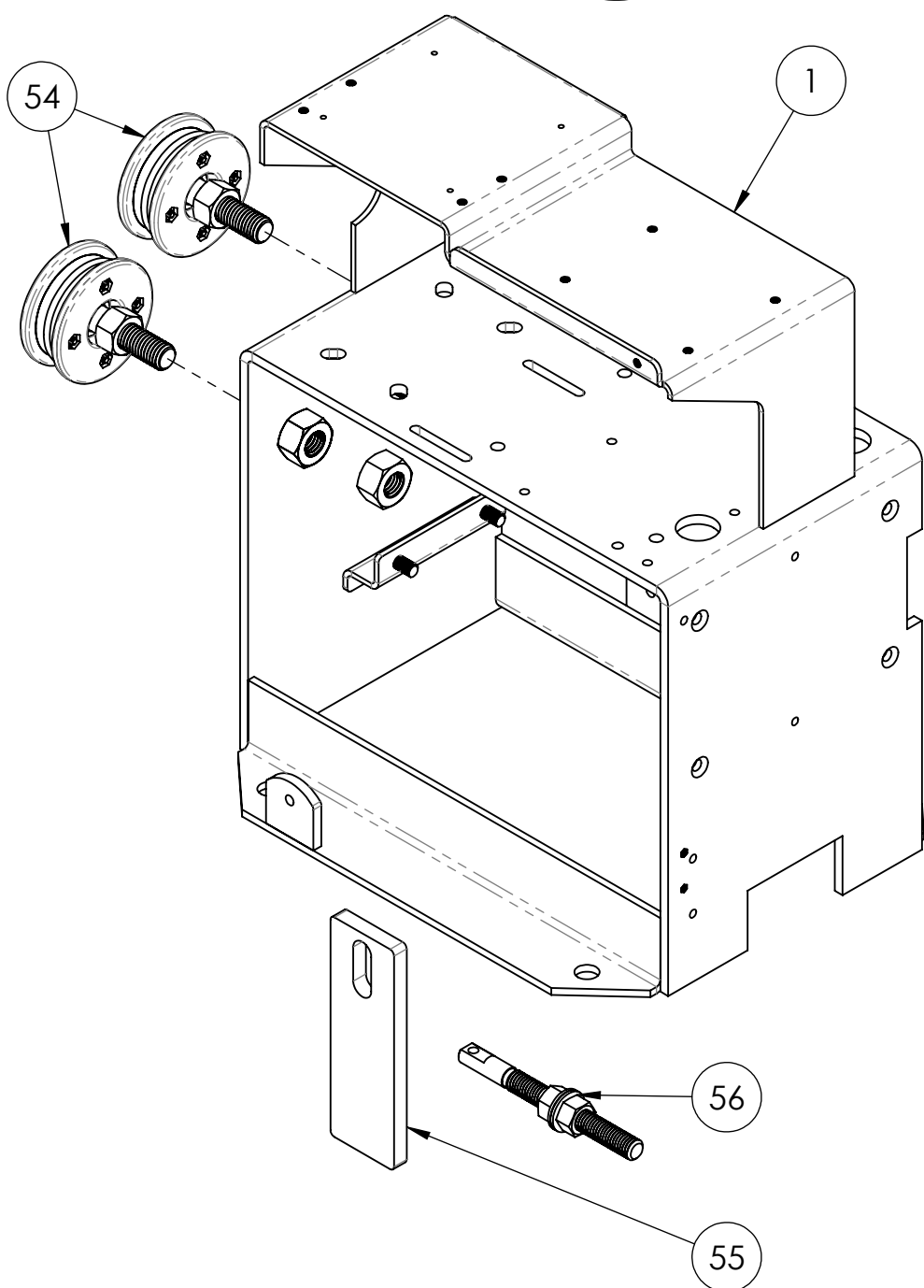
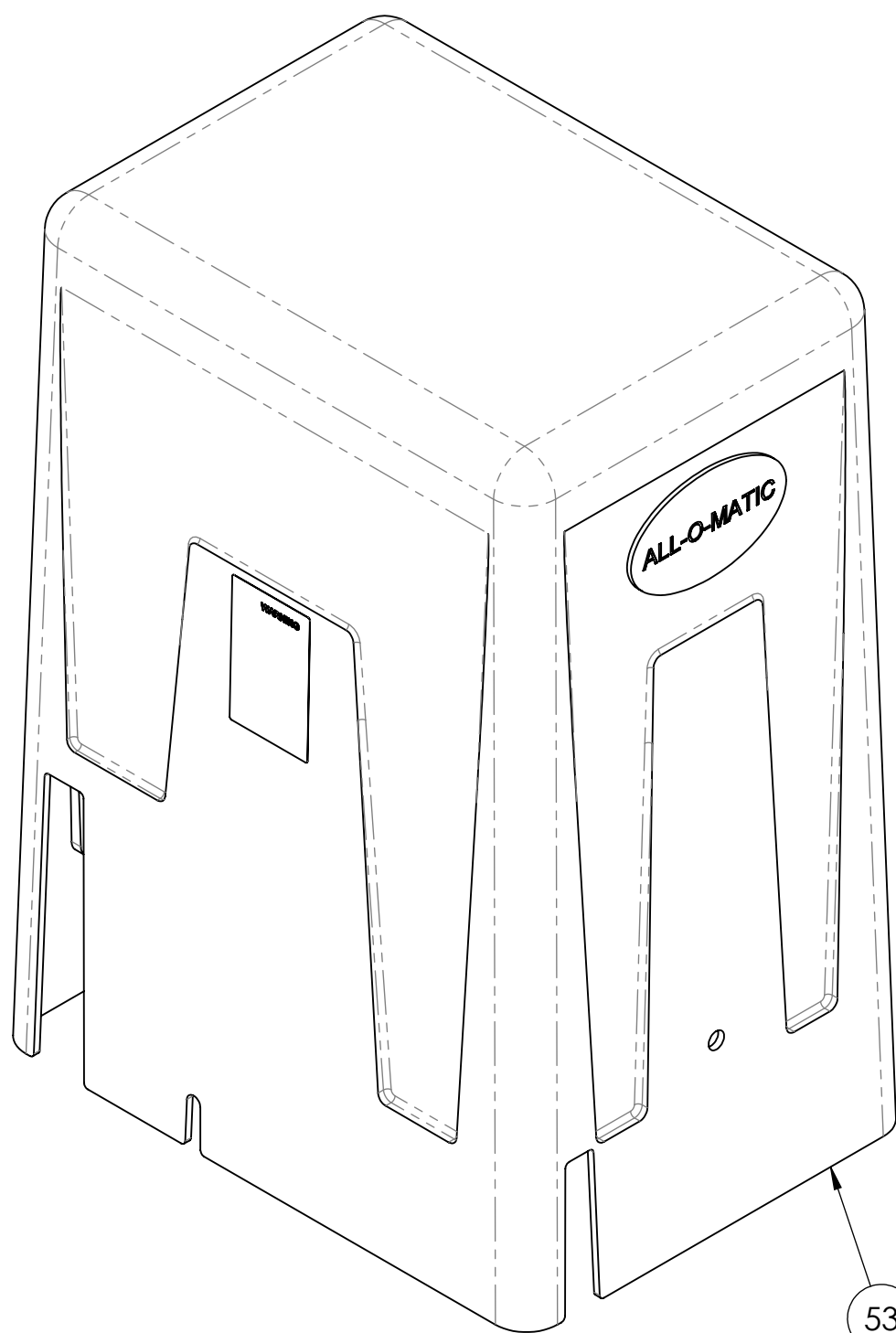
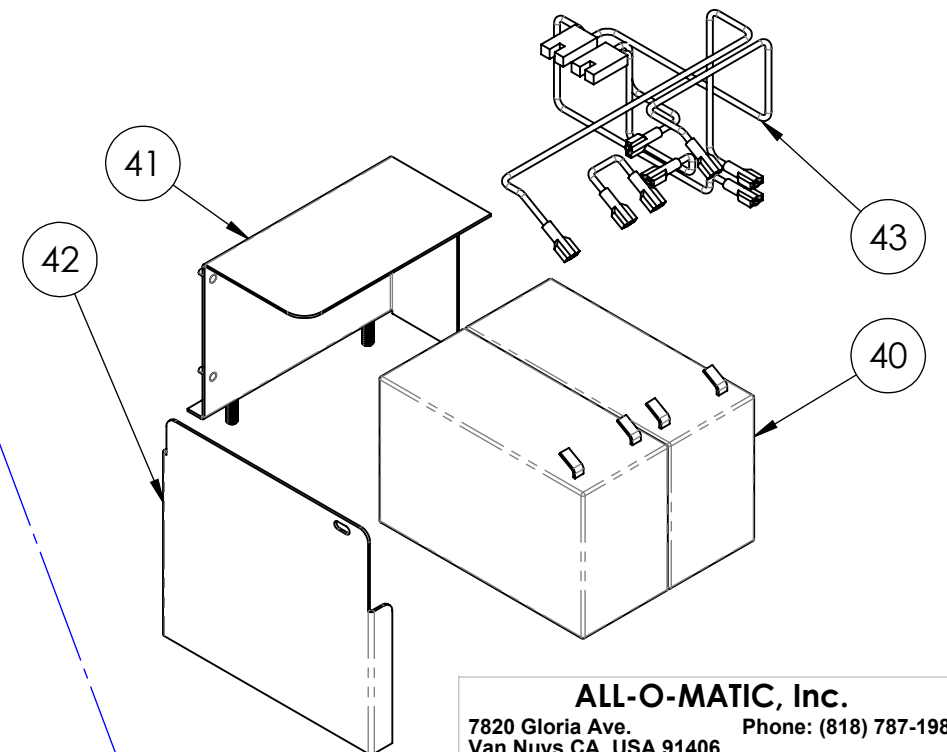

ALL-O-MATIC, Inc.
 7820 Gloria Ave. Phone: (818) 787-1988
 Van Nuys CA, USA 91406
 EMAIL: fortino@allomatic.net

DIMENSIONS ARE IN INCHES
 BREAK SHARP EDGES 10-40
 MACHINED SURFACE FINISH IS
 1.6 MICROMETERS
 DO NOT SCALE DRAWING

THE INFORMATION DISCLOSED HEREIN WAS ORIGINATED BY
 AND IS THE PROPERTY OF ALL-O-MATIC, INC. AND ALL PATENT,
 PROPRIETARY, DESIGN, USE, SALE, MANUFACTURING, AND
 REPRODUCTION RIGHTS THERETO ARE RESERVED BY
 ALL-O-MATIC, INC.

DRAWN BY: S.HUERTA DATE DRAWN: 09/10/2020 CHECKED BY: X DATE CHECKED: X
 MATERIAL: RAW MAT:
 TITLE: DC SLIDERSL-100FP DC
 SHEET 2 OF 2 SCALE: 1:4 DRAWING SIZE: C PART#: SL-100FP DC

1	ECO#	ENGINEERING CHANGE ORDER REVISION DESCRIPTION	BY	CKD	DATE

4

3

2

1