

4

3

2

1

All parts marked in GRAY, please contact PDP



Power Door Products
(914) 698-5083
www.PowerDoorProducts.com

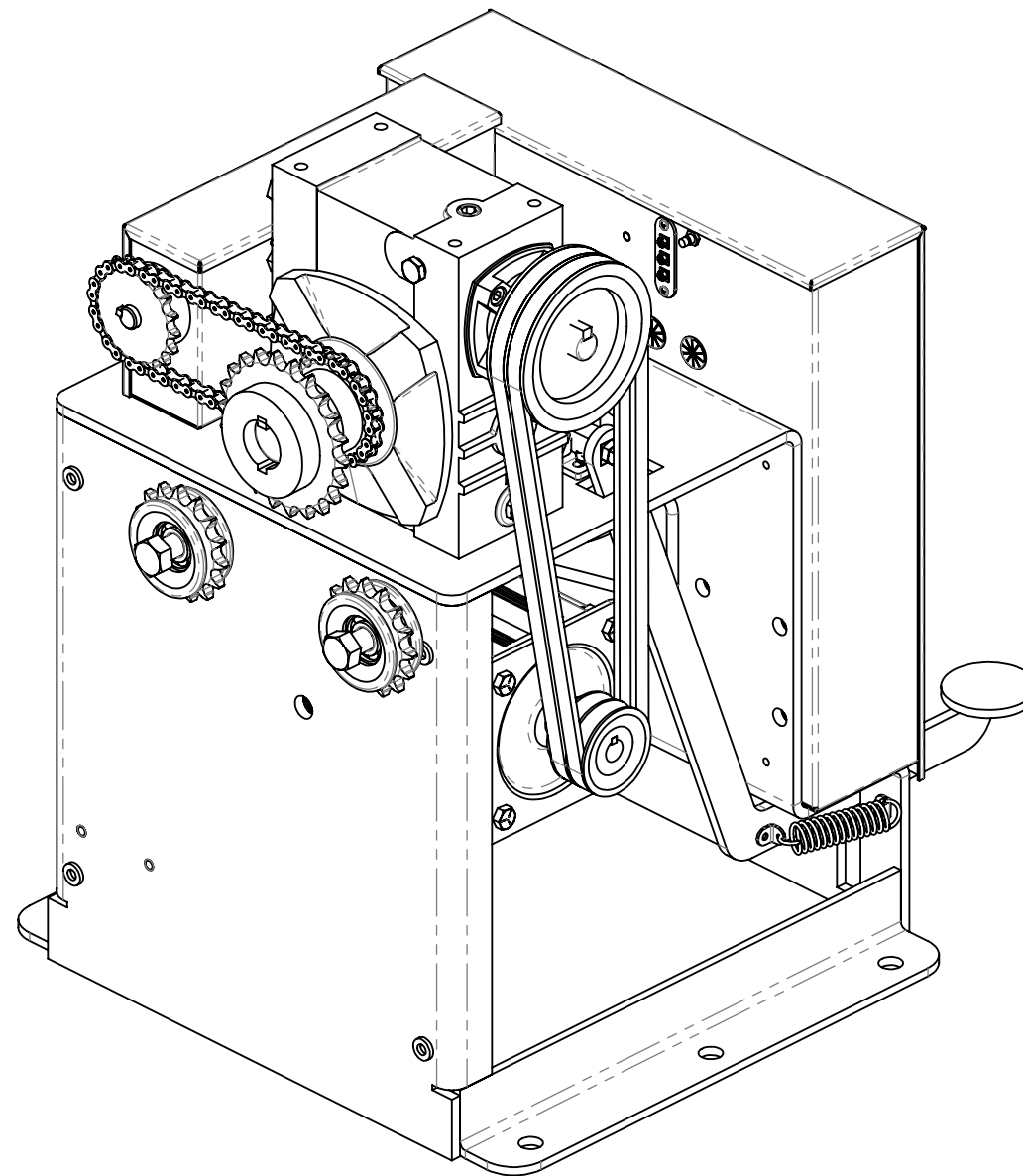
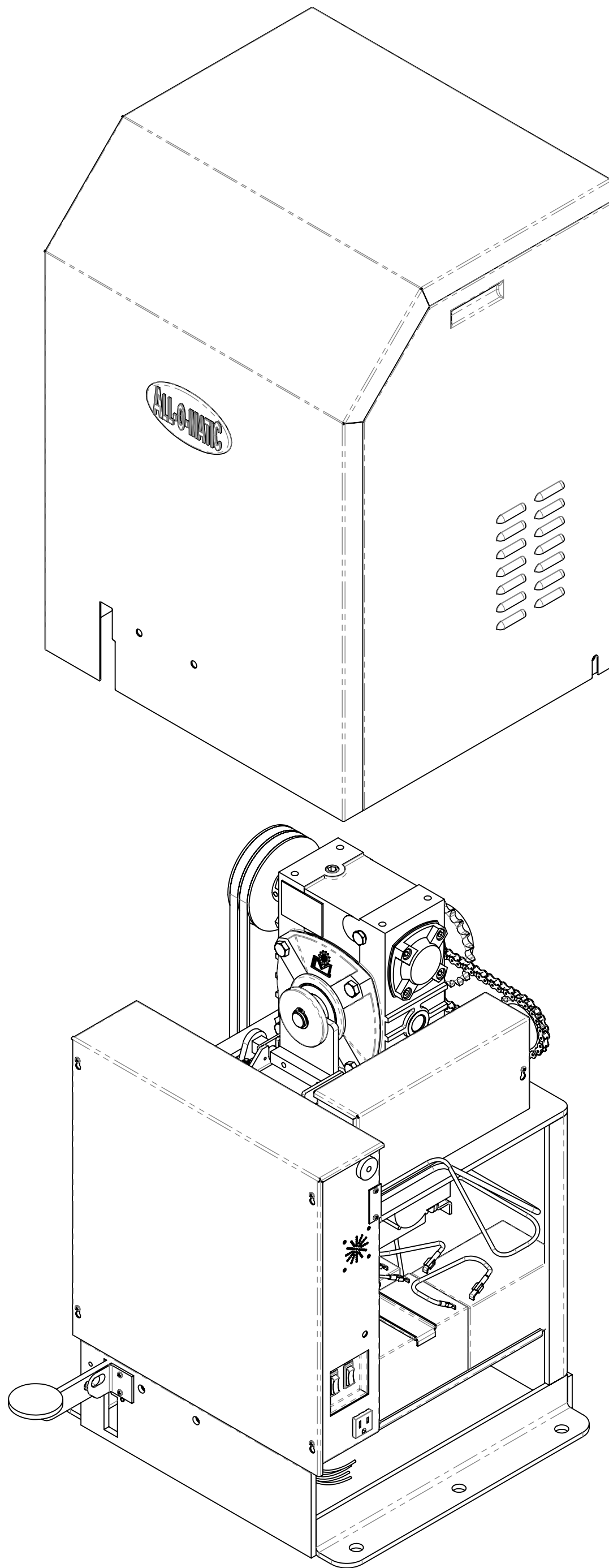

ITEM NO.	DESCRIPTION	PART NUMBER	QTY.
1	FRAME ONLY	SL-175FM	1
2	GEARBOX W/CLUTCH	GBX-175	1
3	GEARBOX PULLEY	2AK49X34	1
4	GEARBOX LIMIT SPROCKET	40B18X1.375	1
5	GEARBOX DRIVE SPROCKET	50B22X1.375	1
6	GEARBOX LIMIT SPROCKET CHAIN	40NPX20	1
7	GEARBOX BELT	4L-370 (AX35)	2
8	2 HP DC MOTOR	MTR-2300	1
9	BLDC MOTOR PULLEY	2AK30X58	1
10	BLDC MOTOR BRACKET	MTR-B175	1
11	CONTROL BOX ASSEMBLY	CBX-AY175	1
12	CONTROL BOX DC CIRCUIT BOARD-36V	BLDC-ULPCB-36V	1
13	CONTROL BOX	CBX-175	1
14	FAN AND THERMOSTAT	TMT-175	1
15	CONTROL BOX ALARM BUZZER	COM-1005	1
16	CONTROL BOX METAL COVER	CBC-175	1
17	CONTROL BOX RESET PUSH BUTTON	COM-1004	1
18	CONTROL BOX ON/OFF POWER SWITCH	COM-1000	2
19	LINE-IN WIRE HARNESS 6"	COM-1016	1
20	CONTROL BOX RADIO RECEIVER STRIP	COM-1003	1
21	POWER SUPPLY BOX 110VAC OUTLET	COM-1001	1
22	LIMIT SHAFT AND SWITCH BOX ASSEMBLY	LSB-AY175	1
23	LIMIT SWITCH BOX	LSB-175	1
24	LIMIT SWITCH BOX COVER	LBC-175	1
25	LIMIT SHAFT SPROCKET	40B18X58	1
26	LIMIT SHAFT	LST-175	1
27	LIMIT SWITCH PLASTIC NUT	COM-1008	2
28	LIMIT SWITCH	COM-1007	2
29	LIMIT SWITCH WIRE HARNESS	LSH-175	1
30	LIMIT SHAFT BEARING - 1/2"	BRG-6202A	1
31	LIMIT SHAFT BEARING 5/8"	BRG-6202B	1
32	LIMIT SWITCH SPRINGS (2)	SPG-7575	2
33	POWER SUPPLY ASSEMBLY	PSB-AY175	1
34	POWER SUPPLY TRANSFORMER	TFR-1000	1
35	POWER SUPPLY BOARD	EMI-PCB	1
36	CONTROL BOX BRIDGE RECTIFIER	COM-1006	2
37	BATTERY WIRE HARNESS COMPLETE (18"&19")	BTY-H175	1
38	14 AH BATTERIES	BTY-1215	3
39	POWER SUPPLY WIRE HARNESS	PSH-175	1
40	BATTERY MOUNTING SHELF	BTB-175	1
41	BATTERY MOUNTING HOLD BRACKET	BTC-175	1
42	FOOT PEDAL RELEASE ASSEMBLY	FPR-AY175	1
43	FOOT PEDAL RELEASE W/TAB	FPR-175	1
44	FOOT PEDAL SQUARE HINGE SHAFT	SHS-175FP	1
45	FOOT PEDAL SPRING	SPG-100FP	1
46	FOOT PEDAL SPLIT PIVOT BRACKET (A)	HPB-175A	1
47	FOOT PEDAL HINGE BRACKET	HSB-175	1
48	FOOT PEDAL SPLIT PIVOT BRACKET (B)	HPB-175B	1
49	FOOT PEDAL SPRING HOOK BRACKET	SHB-175	2
50	FOOT PEDAL FORK	FPF-175	1
51	FOOT PEDAL RELEASE KILL SWITCH	COM-1007P	1
52	LOOP RACK	LPR-2	1
53	LOOP RACK WIRE HARNESS (20")	LPR-H175	1
54	EXTERIOR METAL COVER	EMC-175	1
55	METAL CHAIN IDLER	50BB15	2

ALL-O-MATIC, Inc.
7820 Gloria Ave. Phone: (818) 787-1988
Van Nuys CA, USA 91406
EMAIL: fortino@allomatic.net

DIMENSIONS ARE IN INCHES
BREAK SHARP EDGES 10-40
MACHINED SURFACE FINISH IS
1.6 MICROMETERS
DO NOT SCALE DRAWING
THE INFORMATION DISCLOSED HEREIN WAS ORIGINATED BY
AND IS THE PROPERTY OF ALL-O-MATIC, INC. AND ALL PATENT,
PROPRIETARY, DESIGN, USE, SALE, MANUFACTURING, AND
REPRODUCTION RIGHTS THERETO ARE RESERVED BY
ALL-O-MATIC, INC.

DRAWN BY: S. HUERTA DATE: 07-02-2022 CHECKED BY: F. TARULA DATE: _____

MATERIAL: _____
RAW MAT: _____

TITLE: SL-175DC

SHEET 1 OF 2 SCALE: 1:5 DRAWING SIZE: C PART#: SL-175DC

4

3

2

1

4

3

2

1

POWER SUPPLY BOX ASSEMBLY :
PSB-AY175 (33)

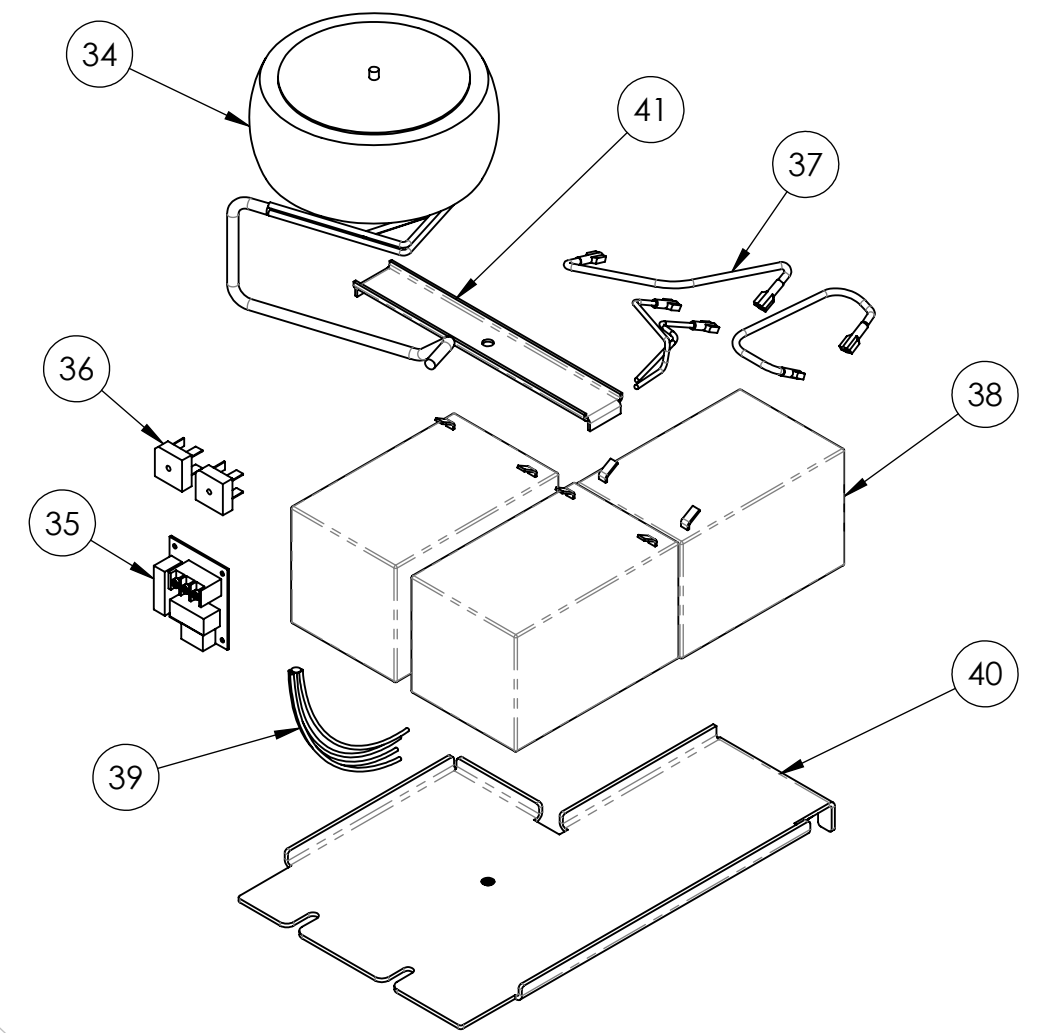
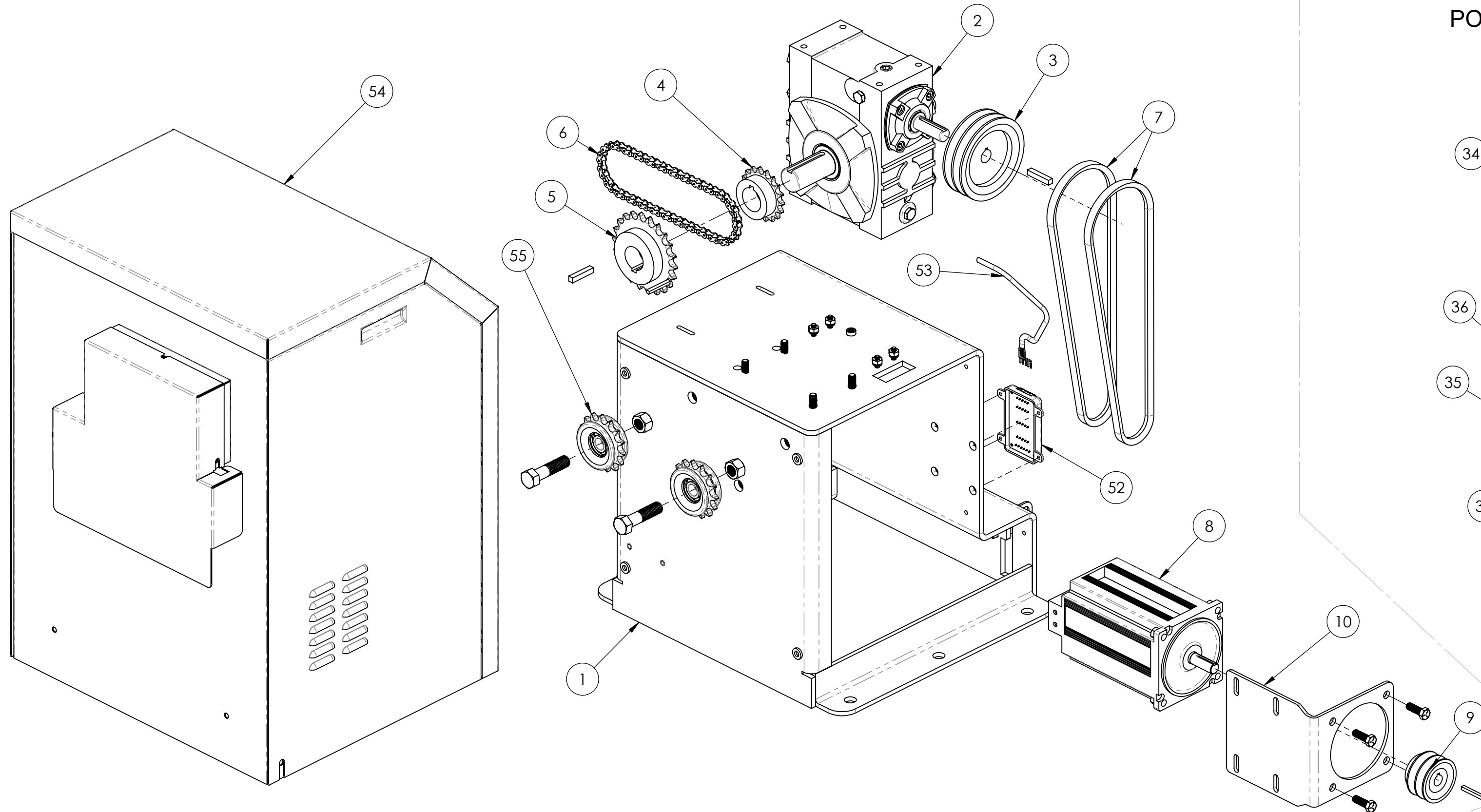

CONTROL BOX ASSEMBLY : CBX-AY175 (11)

LIMIT SWITCH BOX ASSEMBLY : LSB-AY175 (22)

FOOT PEDAL RELEASE ASSEMBLY :
FPR-AY175 (42)

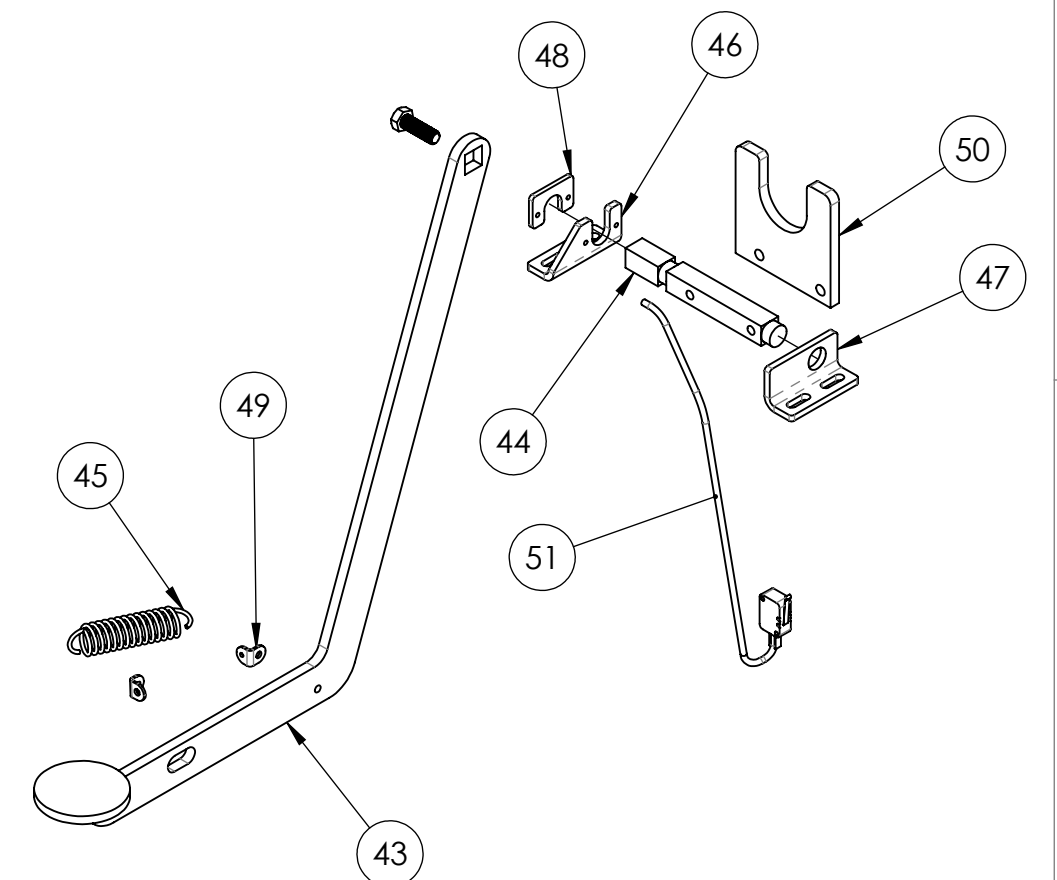
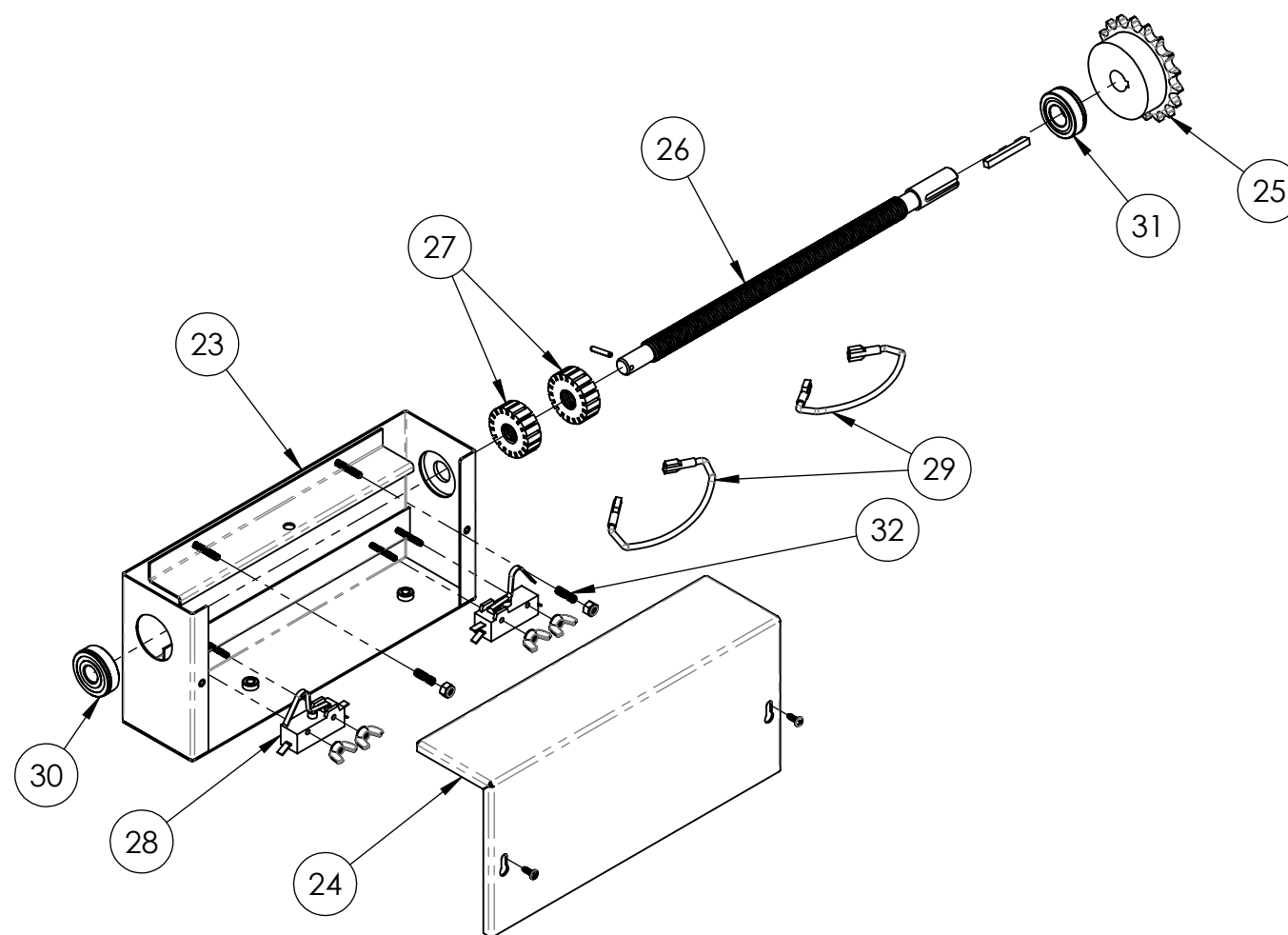
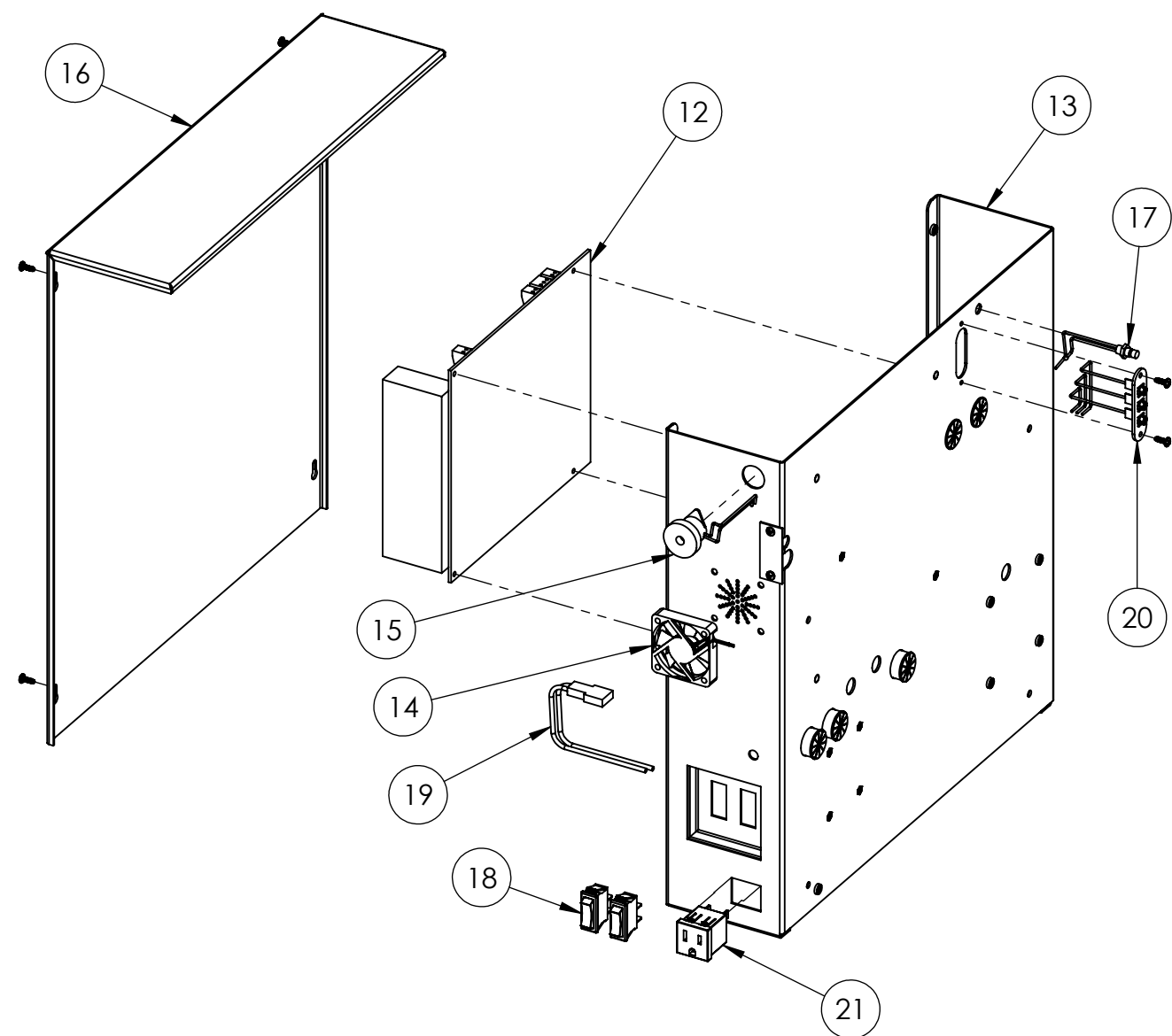

4

3

2

1