

455 D

Control Board

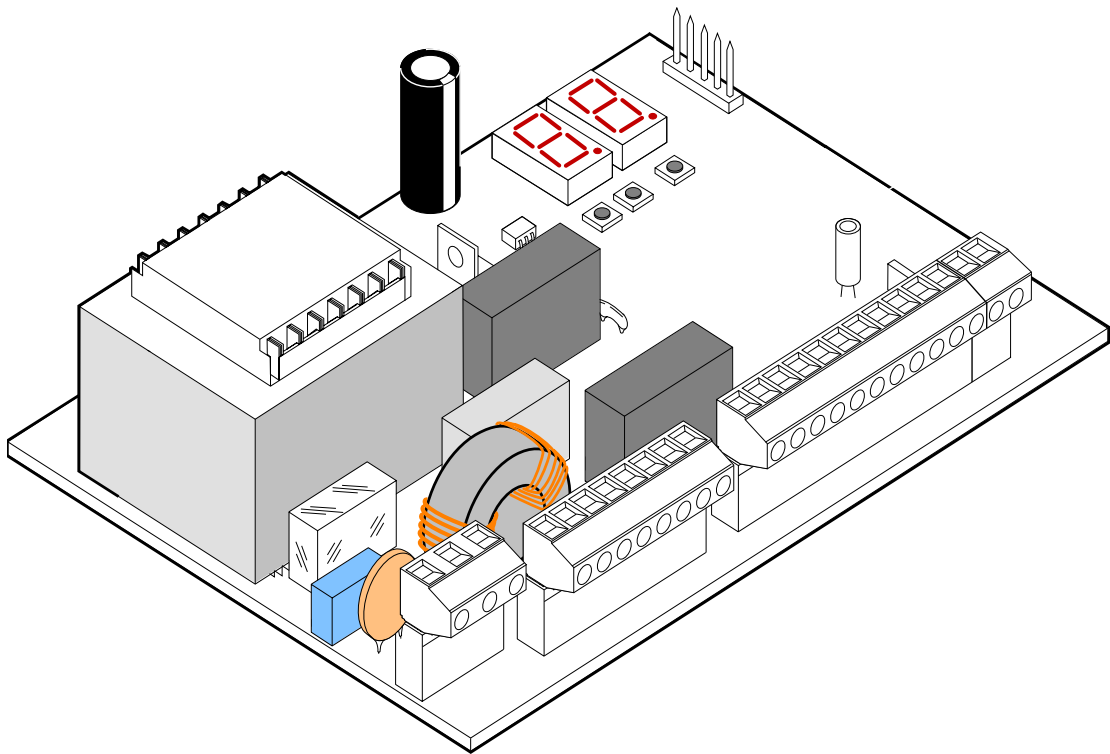

FAAC International Inc.
Headquarter & East Coast Operations
3160 Murrell Rd
Rockledge, FL 32955
Tel. 800 221 8278

FAAC International Inc.
West Coast Operations
17595 Cartwright Rd
Irvine, CA 92614

FAAC

455D CONTROL BOARD

1. General Description

The 455 D control board is used to operate the FAAC High Voltage swing gate operators. It has several operating logics built in, programmable with the help of a display and push-buttons. The board allows connection of various accessories including monitored photocell for compliance with the UL325 standard Ed: 7.

The 455D control board allows the connection of 1 close and up to 2 open entrapment protection devices.

The board should be installed in an enclosure that is conveniently located as close as possible to the gate operator. All electrical connections from the control board to the operator must be made in a weatherproof junction box.

2. Technical Specifications

Input Voltage	115 V~ ± 10% or 230 V~ +6% -10% 50/60 Hz
Input Power	10 W
Motor Max. Load	800 W
Accessories Max. Load	0,5 A
Electric Lock Max. Load	15 VA
Ambient Operating Temperature Range	-4°F to +131°F
Protection Fuses	5A (230V version) 10A (115V Version) 800 mA (accessory)

3. Features

Function Logics:

Semi-automatic / Automatic / Safety Devices / "Stepped" Semi-automatic / "Stepped" Automatic / "Stepped" Safety Devices / Semi-automatic B / Dead-man C

Opening/Closing Time:

Programmable (from 0 to 120 s)

Pause Time:

Programmable (from 0 to 4 min.)

Closing Leaf Delay:

Programmable (from 0 to 4 min.)

Opening Leaf Delay:

2 s (can be excluded)

Thrust Force:

Adjustable on 50 levels for each motor

Terminal Board Inputs:

Open / Open Free Leaf / Stop / Limit-switch / Opening Safety Devices / Closing Safety Devices / Power Supply + Earth.

Terminal Board Outputs:

Flashing Lamp / Motors / 24 VDC Accessories Power Supply / 24 VDC Indicator-Light / Fail Safe / 12 VAC Electric Lock Power Supply

Programmable Functions:

Logic / Pause Time / Thrust Force / Torque at Initial Thrust / Opening and Closing Leaf Delay / Reversing Stroke / Over-Pushing Stroke / Indicator-Light / Pre-Flashing / Electric Lock / Fail Safe / Safety Devices Logic / Assistance Request / Detection Time of Obstacle or Contact Point

Learning Function:

Simple or complete work time learning, with or without Limit-switches

4. Layout and Components

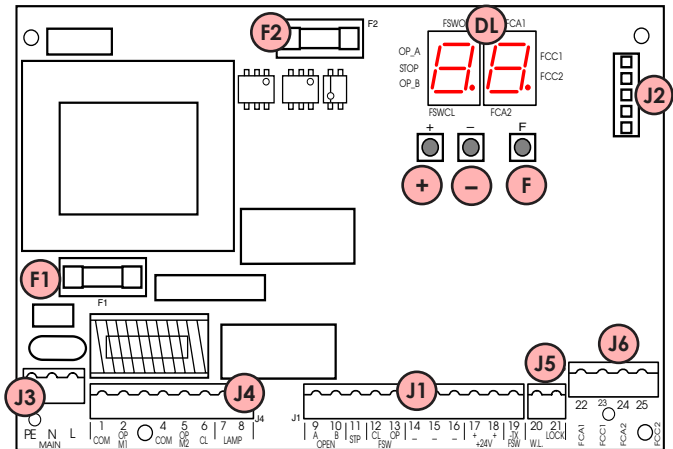

DL STATUS AND PROGRAMMING DISPLAY

J1 LOW VOLTAGE TERMINAL BLOCK

J2 CONNECTOR FOR RADIO RECEIVER

J3 AC POWER SUPPLY TERMINAL BLOCK

J4 MOTORS AND WARNING LAMP TERMINAL BLOCK

J5 INDICATOR-LIGHT AND ELECTRIC LOCK TERMINAL BLOCK

J6 LIMIT-SWITCH TERMINAL BLOCK

F1 MOTORS AND TRANSFORMER PRIMARY WINDING FUSE (F 5A - 230V) (F 10A - 115V)

F2 LOW VOLTAGE AND ACCESSORIES FUSE (T 800mA)

F "F" PROGRAMMING PUSH-BUTTON

- "-" PROGRAMMING PUSH-BUTTON

+ "+" PROGRAMMING PUSH-BUTTON

Connector J2 - Rapid Connection to RP Receivers

The 5 pin J2 connector allows to plug in the FAAC RP radio receivers

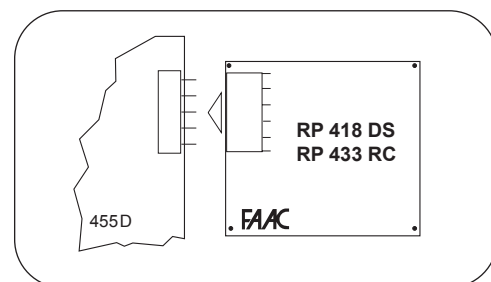

Terminal Block J3 - Power Supply

PE: Earth Connection / Ground

N: AC V~ power supply (Neutral)

L: AC V~ power supply (Line)



The installer is responsible for grounding the operator system, for providing the main power breaker switch, and for making sure that the entire gate system meets all applicable electrical codes.

5. Electric Connections

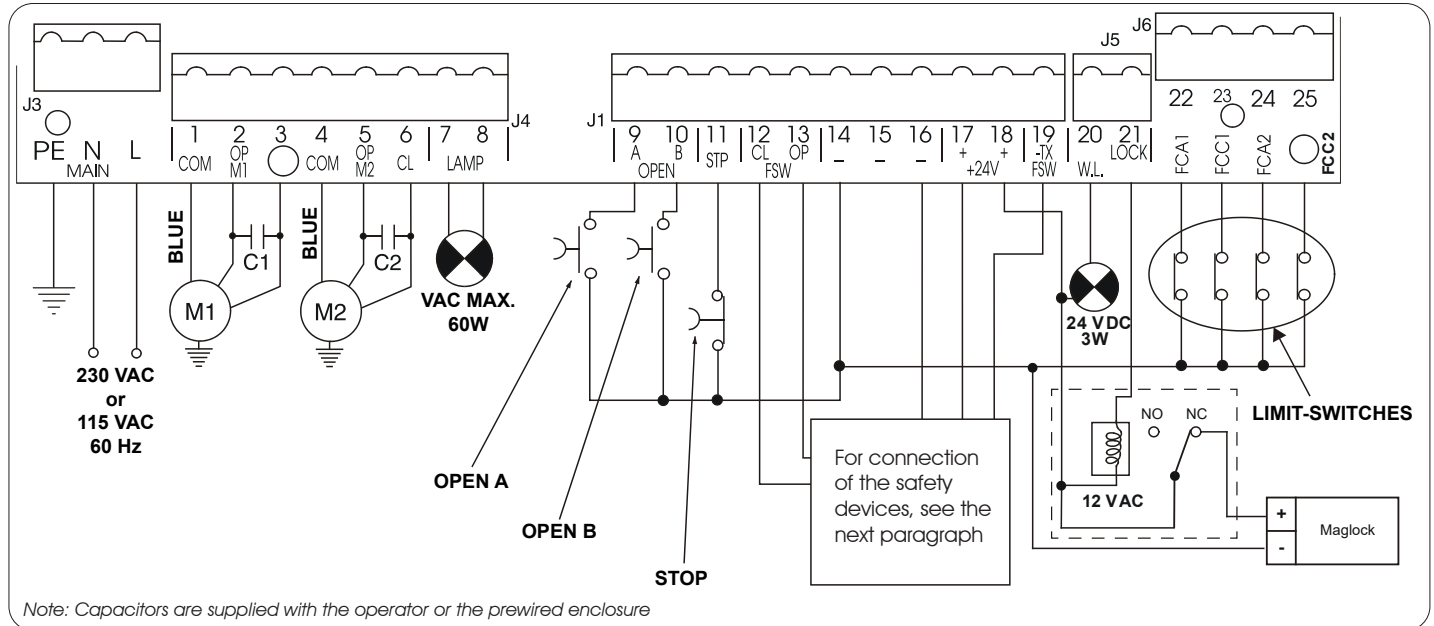

Note: Capacitors are supplied with the operator or the prewired enclosure

Terminal Block J4 - Motors and Warning Lamp

M1: COM / OP / CL: Connection to Motor 1
Must be used for single-leaf configuration

M2: COM / OP / CL: Connection to Motor 2
Cannot be used in single-leaf configurations

LAMP: Warning lamp output (AC V ~)

Terminal Block J1 - Accessories

OPEN A - "Total Opening" Command (N.O.):

Any pulse generator (push-button, detector, etc.) which, by closing a contact, commands opening and/or closing of both gate leaves. To install several full opening pulse generators, connect the N.O. contacts in parallel.

OPEN B - "Partial Opening" Command (N.O.) / Closing:

Any pulse generator (push-button, detector, etc.) which, by closing a contact, commands opening and/or closing of the leaf driven by motor M1. In the B and C logics, it always commands closing of both leaves. To install several partial opening pulse generators, connect the N.O. contacts in parallel. See logic chart for exact operation.

STP - STOP Contact (N.C.):

Any device (e.g. a push-button) which, by opening a contact, is able to stop gate movement. To install several STOP devices, connect the N.C. contacts in series. It also can act as an additional monitored opening safety.

Note: If STOP devices are not used, connect a jumper between the STP terminals and -.

CL FSW - Closing Safety Contact (N.C.):

The closing safety input is used to protect the leaf movement area during closing. While closing, an activation of the the safety device connected to this input will reverse the movement of the gate leaves. This input is inactive during the opening cycle. **at least one monitored safety device must be connected to this input.** See the next paragraph on how to connect a monitored device. If this input is active when the gate is open it will prevent the leaf closing movement.

OP FSW - Opening safety devices contact (N.C.):

The opening safety input is used to protect the leaf movement area during opening. While opening, an activation of the the safety device connected to this input will reverse the movement of the gate leaves. This input is inactive during the closing cycle. To be compliant with the UL325 standard if this input is used to protect an entrapment zone at least one monitored safety device must be connected to it. See the next paragraph on how to connect a monitored device. If this input is active when the gate is closed it will prevent the leaf opening movement.

= - Negative for power supply to accessories

± - 24 VDC - Positive for power supply to accessories

Important: Accessories max. load is 500 mA. To calculate current draw, refer to the instructions for individual accessories.

-TX FSW - Negative Power to photocell transmitters.

This terminal is used for the photocells monitoring feature. Compliance with the UL325 standard requires connecting the transmitter photocell negative power to this input and activating the FAIL SAFE function (see *Advanced Programming*). This will allow the 455 D board to check the correct operation of the safety photocells before each opening or closing cycle.

Terminal Block J5 - Indicator-Light and Electric Lock

W.L. - Power supply to indicator-light

Connect a 24 VDC - 3 W max. indicator-light, if necessary, between this terminal and the +24V supply. To avoid compromising correct operation of the system, do not exceed the indicated power.

LOCK - Power supply to electric lock

If necessary, connect a 12 Vac electric strike lock between this terminal and the +24V power supply. Or connect a 12 Vac relay and a Maglock following the schematic above.

Terminal Block J6 - Limit-Switches

These inputs are dedicated to the connection of opening and closing limit switches

6. Connection of Safety devices

Entrapment protection

To comply with the UL325 standard for gate operators every entrapment zone, as defined in ASTM F2200, must be protected by two independent entrapment protection devices. One of the devices is inherent in the FAAC operators or the control board design, the other can be external, like a photocell or an edge sensor.

See the following picture for the photocells positioning:

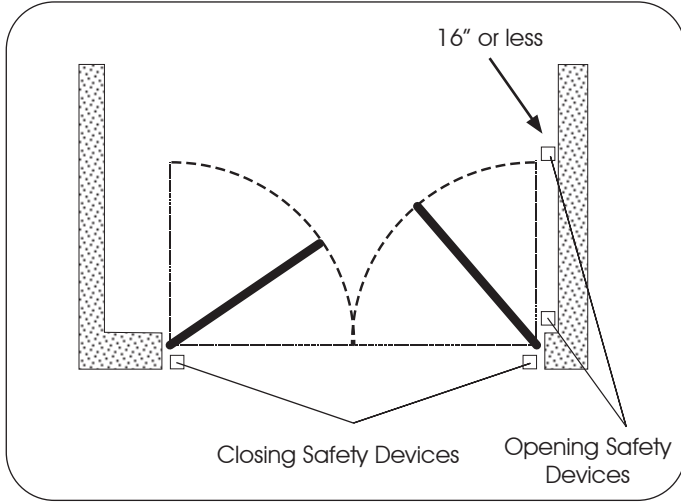

Opening Safety Devices:

Are active only during the gate opening movement, and are suitable for protecting the area between the opening leaves and fixed obstacles (walls, etc) against the risk of entrapment

Closing Safety Devices:

Are active only during the gate closing movement, and are suitable for protecting the closing area against the risk of entrapment.

Monitored Devices:

Additionally the UL325 standard requires that every external entrapment protection device must be monitored for presence and correct operation. The closing safety devices are always monitored, see the following picture for the wiring of a pair of photocells as closing safety devices.

NOTE: one closing safety device must always be connected for the system to work.

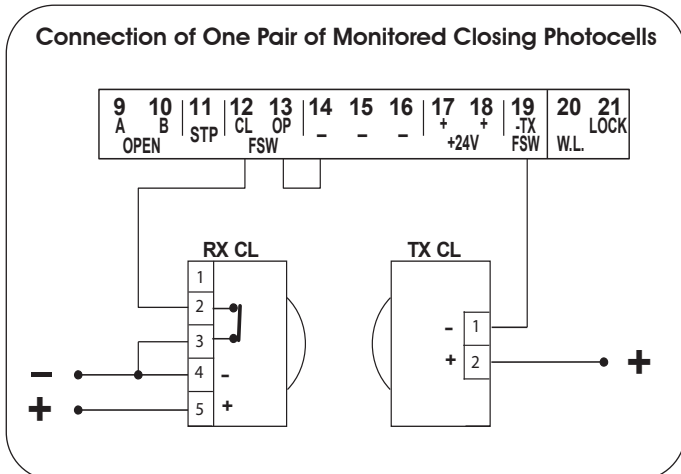

Monitoring of the opening safety devices must be enabled in the board configuration. To enable it enter in advanced programming by pressing and holding "F" and then press "+", scroll to the "FS" parameter and select "Active".

Display	Function	Default
FS	<p>OPENING FAIL SAFE:</p> <p>If this function is activated, it enables the monitoring of the opening safety photocell before the opening movement. If the test fails the gate does not open.</p> <p>4 = Active 70 = Disabled</p>	70

Connection of One Pair of Monitored Closing Photocells and One Pair of Monitored Opening Photocells

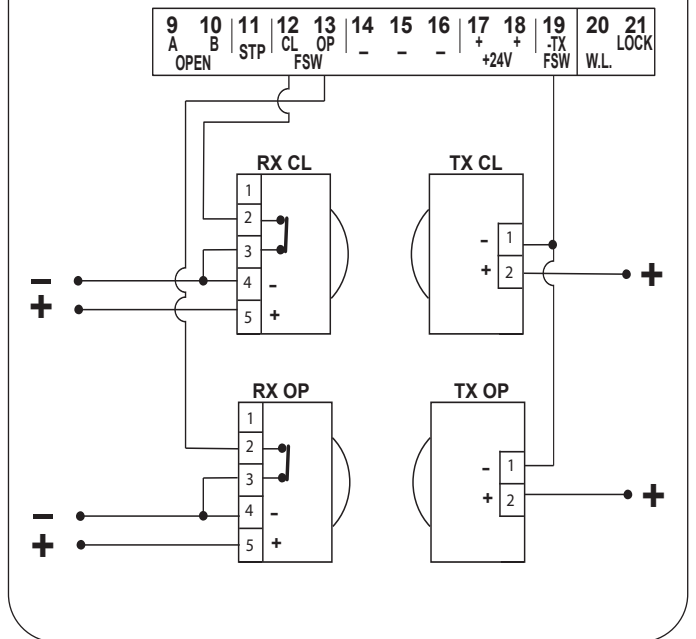

If an additional monitored opening safety device is needed it can be connected to the STP input. The "OP" parameter in the board configuration must be set to active

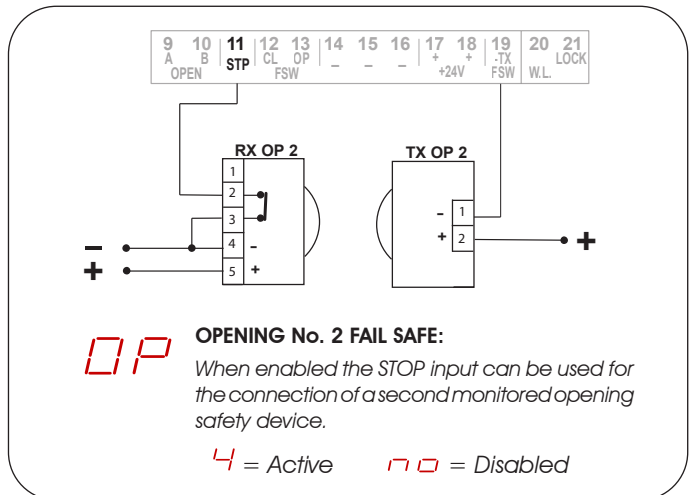

Only one monitored photocell can be connected to the Closing or Opening safety inputs. More than one photocell or other device can be connected to the safety inputs, but they will not be monitored.

Other devices connected to the safety inputs must have normally closed contacts and wired in series with the main monitored sensor.

See the following example of one closing safety monitored photocell and one non monitored one.

See the following connections diagrams for example of opening/closing safety wiring.

Connection of Two Pairs of Closing Photocells, One Monitored and One Non Monitored

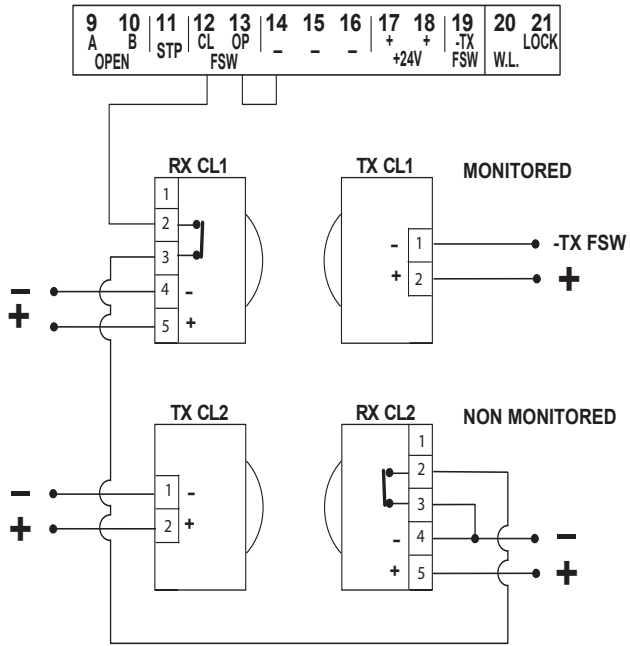

Connection of a pair of Monitored Closing Photocells, and one pair of Non Monitored Opening/Closing Photocell

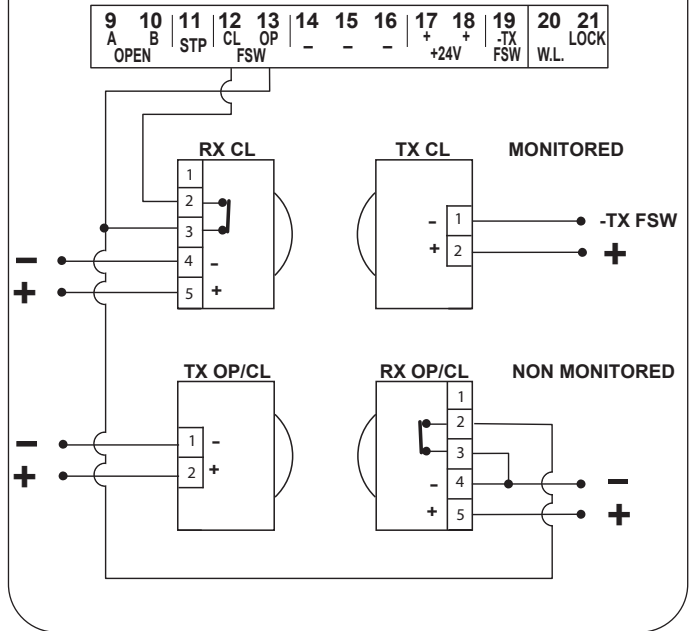

Connection of One Pair of Monitored Closing Photocells, One Pair of Monitored Opening Photocells and One pair of Non Monitored Opening/Closing Photocells

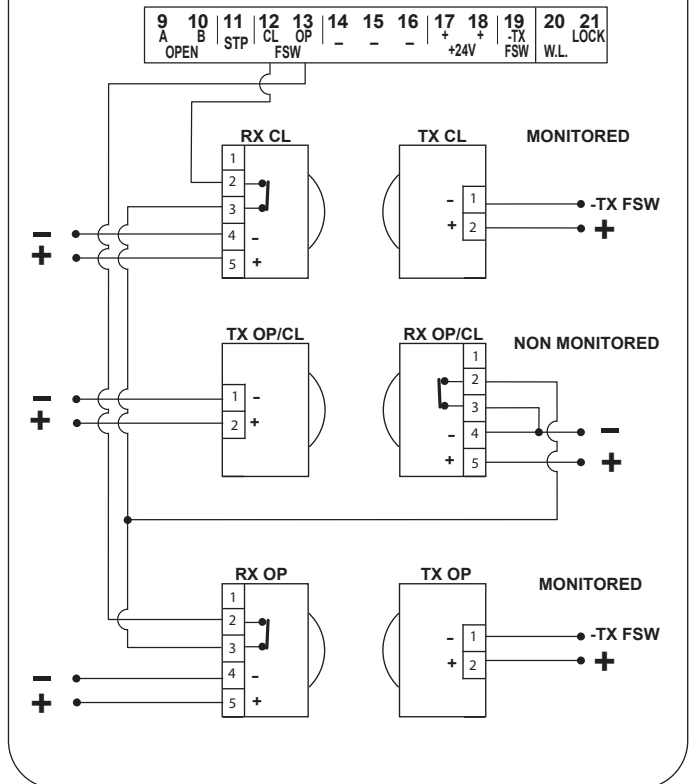

Opening/Closing Safety Devices:

They operate during the gate opening and closing movements and are suitable to protect the opening and closing areas against the risk of impact. Typically these photocells work in combination with other monitored photocell protecting closing or opening entrapment zones. In that case they can't be monitored so they can only protect against potential impact on vehicles.

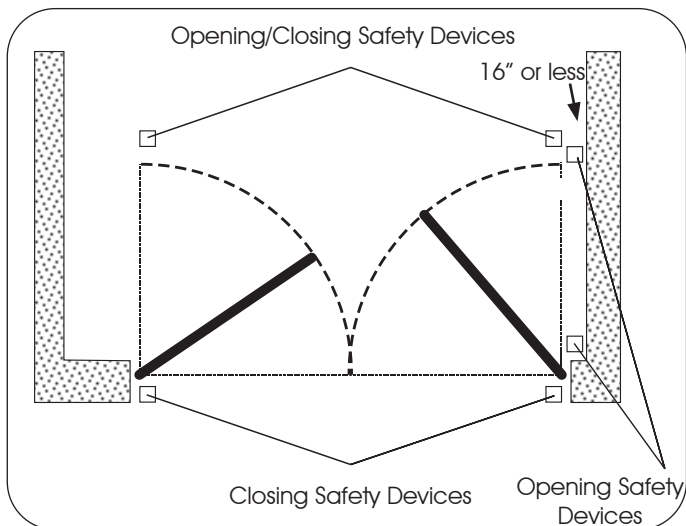

7. Operating Logics

This is a brief description of the main operating logics of the system. For a complete description please refer to Table 3

- E (semi-automatic): This mode requires a command to open and a command to close. A second command during opening stops the gate. A second command during closing reopens the gate.
- A (automatic): The gate opens on command and automatically closes after the pause time. A second command while opening is ignored; a second command during the pause phase interrupts the pause time; a second command during closing reopens the gate. A maintained open command will hold the gate open.
- S (security): The security mode is like A logic except that a second command during opening immediately closes the gate. A maintained open command will not hold the gate open.
- EP (semi-automatic, step by step): This mode requires a command to open and a command to close. A second command during opening or closing causes the gate to stop. A third command then reverses the previous motion of the gate.
- B (manned, pulsed): This mode is designed for guard station use and requires a three button switch (pulsed) to open, close, and stop the gate.
- C (manned and constant): This mode requires constant pressure switches. One to open and one to close. No pressure on a switch stops the gate.

8. Programming

To program the 455D Control Board, you have to access "PROGRAMMING" mode. Programming is split into two parts: BASIC and ADVANCED.

Basic Programming:

To access BASIC PROGRAMMING, press key **F**:

- Press and hold **F**, the unit will display the name of the first function / parameter.
- When you release the key, the unit will display the parameter's current value.
- Value can be modified with keys + and - .
- Press and hold **F** again, the unit will display the name of the next function / parameter.
- When you reach the last function, press **F** to exit the program, the display resumes monitoring input status.
- IMPORTANT: Make sure to exit programming mode otherwise the changes will not be saved.

The following table displays the sequence of functions accessible in BASIC PROGRAMMING:

BASIC PROGRAMMING <small>press F</small>		
Display	Function	Default
LO	OPERATING LOGICS (see tab. 3/a - h): E = Semi-automatic A = Automatic S = Security EP = "Stepped" Semi-automatic AP = "Stepped" Automatic SP = "Stepped" Security b = Manned, pulsed c = Manned, constant	E
PA	PAUSE TIME: This has effect only when automatic logic is selected. Adjustable from 0 to 59 secs. in one-second increments. Subsequently, display changes to minutes and tenths of seconds (separated by a decimal point), time is adjusted in 10-second increments, up to 4.1 minutes max. Thus, if the unit displays 2.5, Pause Time is 2 mins. and 50 secs.	0
F1	LEAF 1 FORCE: Adjusts thrust of Motor 1. 1 = minimum force 50 = maximum force (*)	25
F2	LEAF 2 FORCE: Adjusts thrust of Motor 2. 1 = minimum force 50 = maximum force (*)	25
cd	LEAF 1 CLOSING DELAY: Delays closing start of leaf 1 with respect to leaf 2. Adjustable from 0 to 4.1 minutes (see Pause Time).	0
EL	TIME LEARNING (see Section 10): Enables the selection between "simple" learning and "complete" (manual choice of deceleration and stop points) learning. Simple Learning: (+) ≈ 1 s. Complete Learning: (+) > 3 s.	
in	Exit from programming and return to inputs status monitoring.	

(*) For hydraulic operators, set force to the maximum level.

Advanced Programming:

To access ADVANCED PROGRAMMING, press and hold key F and then press key +:

- Release key +, the unit displays the name of the first function.
- Release key F, modify the value of the function with keys + and -.
- Press and hold key F, the unit displays the name of the next function, and if you release it, the value that can be modified with keys + and -.
- When you reach the last function, press F to exit the program, the unit resumes monitoring input status.

The following table shows the sequence of functions accessible in ADVANCED PROGRAMMING:

ADVANCED PROGRAMMING (F) + (+)		
Display	Function	Default
60	MAXIMUM TORQUE AT INITIAL THRUST: The motors operate at maximum torque (ignoring the torque setting) at start of movement. Useful for heavy leaves. 4 = Active n0 = Disabled	n0
c5	LAST STROKE AT CLOSING: The motors are activated at full speed for 1 second to facilitate locking of the electric lock. 4 = Active n0 = Disabled	n0
r5	REVERSING STROKE: Before opening, while the gate is closed, the motors thrust to close for 2 seconds thus facilitating release of the electric lock. 4 = Active n0 = Disabled	n0
od	LEAF 2 OPENING DELAY (2 s): Enables delayed start (at opening) of leaf 2, avoiding interference between leaves. 4 = Active n0 = Disabled	n0
F5	OPENING FAIL SAFE: If this function is activated, it enables the monitoring of the opening safety photocell before the opening movement. If the test fails the gate does not open. 4 = Active n0 = Disabled	n0
PF	PRE-FLASHING (5 s): Activates the flashing lamp for 5 seconds before start of movement. 4 = Active n0 = Disabled	n0
EL	ELECTRIC LOCK ON LEAF 2: For using the electric lock on leaf 2 instead of on leaf 1. 4 = Active n0 = Disabled	n0

Display	Function	Default
SP	INDICATOR-LIGHT: 0 : the output functions as a standard indicator-light (ON at opening and pause, flashing at closing, and OFF when gate is closed). 1 : the output is ON when the gate is open or in pause. OFF in all other conditions. 2 : the output is ON when the gate is closed. OFF in all other conditions. All other values correspond to the extra time compared to normal work time (opening or closing) when the output can be used - via a relay - to power a courtesy light. Time can be adjusted from 1 to 59 sec. in 1 sec. steps, and from 10 to 41 min. in 10 sec. steps.	0
Ph	CLOSING PHOTOCELLS REVERSE AT RELEASE: Enable this function if you want the closing photocells to stop movement and reverse at release. Default setting is immediate reverse. 4 = Active n0 = Disabled	n0
OP	OPENING No. 2 FAIL SAFE: When enabled the STOP input can be used for the connection of a second monitored opening safety device 4 = Active n0 = Disabled	n0
AS	ASSISTANCE REQUEST (combined with next function): If activated, at the end of countdown (settable with the next function i.e. "Cycle programming") it affects 8 s of pre-flashing at every Open pulse (job request). Can be useful for setting scheduled maintenance jobs. 4 = Active n0 = Disabled	n0
nC	CYCLE PROGRAMMING: For setting countdown of system operation cycles. Settable (in thousands) from 0 to 99 thousand cycles. The displayed value is updated as cycles proceed. This function can be used to check use of the board or to exploit the "Assistance request".	0
EC	EXTRA WORK TIME: If reversing occurs, and if the leaf does not reach its end contact point, you can activate this function to increase work time. 4 = Active n0 = Disabled	n0
In	Exit from programming and return to inputs status monitoring.	

NOTE: Parameter modifications take effect immediately. Exit out of programming to save changes. If the equipment is powered down before returning to normal status monitoring, any unsaved modifications will be lost.

To restore programming defaults, press and hold the three buttons +, -, F simultaneously for 5 seconds.

9. Start-up

LED Indicators:

The board has a two-digit display. When not in "PROGRAMMING" mode, this display is used to indicate the status of inputs. The figure below shows how the LED segments are mapped to the corresponding inputs.

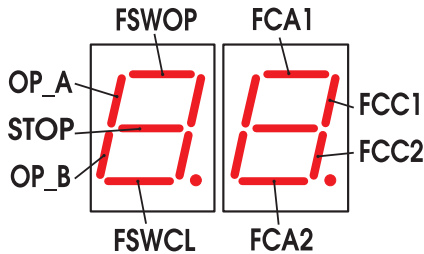

The table below shows the status of the LEDs in relation to the status of the inputs.

Note the following: **LED ON** = closed contact
LED OFF = open contact

Operation of the Status Signaling LEDs

LEDs	ON	OFF
OP_A	Command activated	Command inactive
OP_B	Command activated	Command inactive
STOP	Command inactive	Command activated
FSWCL	Safety devices clear	Safety devices triggered
FSWOP	Safety devices clear	Safety devices triggered
FCA1 (if used)	Limit switch free	Limit switch triggered
FCC1 (if used)	Limit switch free	Limit switch triggered
FCC2 (if used)	Limit switch free	Limit switch triggered
FCA2 (if used)	Limit switch free	Limit switch triggered

The status of the LEDs while the gate is closed at rest are shown in bold.

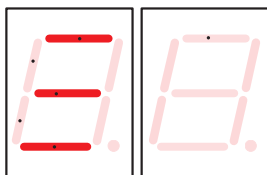

This is the normal status of the display with all the safety inputs clear and no activation signal present

Rotation direction and force check:

1. Program the functions of the 455 D control board according to need, as previously shown.
2. Turn power off to the control board.
3. Release the operators and manually move the gate to the mid-point of the opening angle.
4. Re-lock the operators.
5. Restore power.
6. Send an opening command on the OPEN A input and verify that the gate leaves start moving towards the open position

Note: If the first OPEN A pulse starts a closing movement, turn power off and reverse the phases of the electric motor (red and black wires) on the 455 D control board.

7. Check force setting of the motors, modify if necessary.

Note: For hydraulic operators, like the 400, force should be programmed to maximum level (50)

8. Stop leaf movement with a pulse on the STOP input or turning off power.
9. Release the operators, close the leaves and re-lock the operators.

Opening/closing time is established by a time learning procedure which can be accomplished in "simple" or "complete" modes. The simple mode doesn't allow a slow down phase in the operator, while the complete mode does.

The slow down can be useful to reduce the mechanical stress on the gate, but it can create problems in high wind conditions.

10. Learning Operating Times



WARNING: During the learning procedure, safety devices are disabled! Avoid crossing the leaf movement area when this operation is carried out.

Make sure travel limit mechanical stops are present.

- SIMPLE LEARNING (Without Slow Down):

Check that the leaves are closed. Enter "BASIC PROGRAMMING," select the TIME LEARNING function and then press the + push-button for **1 second**. The display begins flashing and the leaves begin to open.

As soon as the leaves reach the opening contact point, provide an OPEN A pulse (with the key operated push-button or with the radio control) to stop the movement. The leaves stop and the display stops flashing.

Press push-button **F** to exit and save the programming. The procedure is complete and the gate is ready to operate.

- COMPLETE LEARNING (With Slow Down):

Check that the leaves are closed. Enter "BASIC PROGRAMMING," select the TIME LEARNING function and then press the + push-button for more than **3 seconds**. The display begins flashing and leaf 1 begins to open. The following functions can be performed by sending OPEN A pulses (by key push-button or radio control).

A total of 8 OPEN A commands required:

1. Slow down at opening of leaf 1
2. Leaf 1 stops at opening and leaf 2 begins its opening movement
3. Slow down at opening of leaf 2
4. Leaf 2 stops at opening and immediately begins its closing movement
5. Slow down at closing of leaf 2
6. Leaf 2 stops at closing and leaf 1 begins its closing movement
7. Slow down at closing of leaf 1
8. Leaf 1 stops at closing

When the display stops flashing, press push-button **F** to exit and save the programming. The procedure is complete and the gate is ready to operate.

Notes:

- If you wish to eliminate deceleration in certain stages, wait for the leaf to reach its stop-limit and supply 2 consecutive Open pulses (by 1 second).
- If only one leaf is present, the entire sequence must nevertheless be completed. When the leaf has finished opening, supply 5 Open pulses until the leaf begins to close, and then resume normal operation.

11. Final Tests

Once programming is complete and the proper operating times are stored in the board's memory perform a complete test the system. Verify that the operator(s) run properly and, most importantly, check that force is adequately adjusted and that safety devices are operating correctly.

After simple or complete learning the board will add 3 sec. to the programmed time so the operators will run against the stops.

Monitored safety test:

IMPORTANT: To make sure that the safety photocells protecting entrapment zones are monitored properly install a temporary jumper on the N.C. output of the photocell and give an OPEN A command. The gate must not move. otherwise check the wiring of the photocells and make sure that FAIL SAFE is enabled in Advanced Programming

12. Operating Modes Detailed Description

Tab. 3/a

PULSES						
Logic "E"	OPEN-A	OPEN-B	STOP	OPENING SAFETY DEVICES	CLOSING SAFETY DEVICES	OP/CL SAFETY DEVICE
GATE STATUS						
CLOSED	Opens the leaf	Opens single leaf		No effect (OPEN disabled)	No effect	No effect (OPEN disabled)
OPEN	Re-closes the leaf immediately (3)			No effect (if on part.opng. OPEN A disabled)	No effect (3) (OPEN disabled)	No effect (OPEN disabled)
CLOSING	Re-opens the leaf immediately		Stops operation	No effect (saves OPEN)	see paragraph 5.2.	Locks and, on release, reverses to open
OPENING	Stops operation (3)			Reverses to close	No effect	Locks and, on release, continues opening
LOCKED	Closes the leaf (with Closing Safety devices engaged, opens at the 2nd pulse) (3)		No effect (OPEN disabled)	No effect	No effect	No effect (OPEN disabled)

Tab. 3/b

PULSES						
Logic "A"	OPEN-A	OPEN-B	STOP	OPENING SAFETY DEVICES	CLOSING SAFETY DEVICES	OP/CL SAFETY DEVICE
GATE STATUS						
CLOSED	Opens the leaf and closes it after pause time (1)	Opens single leaf and closes after pause time (1)		No effect (OPEN disabled)	No effect	No effect (OPEN disabled)
OPEN on PAUSE	Reloads pause time (1)(3)			No effect (if on part.opng. OPEN A disabled)	Reloads pause time (1) (3)	Reloads pause time (1) (OPEN disabled)
CLOSING	Re-opens the leaf immediately (1)		Stops operation	No effect (saves OPEN)	see paragraph 5.2.	Locks and, on release, reverses to open
OPENING	No effect (1) (3)			Reverses to close	No effect	Locks and, on release, continues opening
LOCKED	Closes the leaf (3)		No effect (OPEN disabled)	No effect	No effect	No effect (OPEN disabled)

Tab. 3/c

PULSES						
Logic "S"	OPEN-A	OPEN-B	STOP	OPENING SAFETY DEVICES	CLOSING SAFETY DEVICES	OP/CL SAFETY DEVICE
GATE STATUS						
CLOSED	Opens the leaf and closes it after pause time	Opens single leaf and closes after pause time		No effect (OPEN disabled)	No effect	No effect (OPEN disabled)
OPEN on PAUSE	Re-closes the leaf immediately (3)			No effect (if on part.opng. OPEN A disabled)	On release, closes after 5" (OPEN disabled) (3)	On release, closes after 5" (OPEN disabled)
CLOSING	Re-opens the leaf immediately		Stops operation	No effect (saves OPEN)	see paragraph 5.2.	Locks and, on release, reverses to open
OPENING	Re-closes the leaf immediately (3)			Reverses to close	No effect (saves OPEN)	Locks and, on release, continues opening
LOCKED	Closes the leaf (3)		No effect (OPEN disabled)	No effect	No effect	No effect (OPEN disabled)

Tab. 3/d

PULSES						
Logic "EP"	OPEN-A	OPEN-B	STOP	OPENING SAFETY DEVICES	CLOSING SAFETY DEVICES	OP/CL SAFETY DEVICE
GATE STATUS						
CLOSED	Opens the leaf	Opens leaf for the partial opening time		No effect (OPEN disabled)	No effect	No effect (OPEN disabled)
OPEN	Re-closes the leaf immediately (3)			No effect (if on part.opng. OPEN A disabled)	No effect (OPEN disabled) (3)	No effect (OPEN disabled)
CLOSING	Stops operation		Stops operation	No effect (saves OPEN)	see paragraph 5.2.	Locks and, on release, reverses to open
OPENING	Stops operation (3)			see paragraph 5.2.	No effect	Locks and, on release, continues opening
LOCKED	Restarts movement in reverse direction (3) (always closes after a Stop)		No effect (OPEN disabled)	No effect (if it must open, it disables OPEN)	No effect (if it must close, it disables OPEN)	No effect (OPEN disabled)

(1) If maintained, it prolongs the pause until disabled by the command (timer function)

(2) If a new pulse occurs within 2 seconds after reversing, it immediately stops operation.

(3) During the partial opening cycle, an OPEN A pulse causes total opening.

NB.: Effects on other active pulse inputs in brackets.

Tab. 3/e

PULSES						
Logic "AP"	OPEN-A	OPEN-B	STOP	OPENING SAFETY DEVICES	CLOSING SAFETY DEVICES	OP/CL SAFETY DEVICE
GATE STATUS						
CLOSED	Opens the leaf and closes it after pause time	Opens single leaf and closes after pause time	No effect (OPEN disabled)	No effect (OPEN disabled)	No effect	No effect (OPEN disabled)
OPEN on PAUSE	Stops operation (3)	Stops operation (3)	Stops operation	No effect (if on part.opng., OPEN A disabled)	Reloads pause time (3) (OPEN disabled)	Reloads pause time (OPEN disabled)
CLOSING	Re-opens the leaf immediately			No effect (saves OPEN)	see paragraph 5.2.	Locks and, on release, reverts to open
OPENING	Stops operation (3)	Stops operation (3)		Reverts to close	No effect	Locks and, on release, continues opening
LOCKED	Closes the leaf (with Closing Safety devices engaged, opens at the 2nd pulse) (3)		No effect (OPEN disabled)	No effect	No effect	No effect (OPEN disabled)

Tab. 3/f

PULSES						
Logic "SP"	OPEN-A	OPEN-B	STOP	OPENING SAFETY DEVICES	CLOSING SAFETY DEVICES	OP/CL SAFETY DEVICE
GATE STATUS						
CLOSED	Opens the leaf and closes it after pause time	Opens single leaf and closes after pause time	No effect (OPEN disabled)	No effect (OPEN disabled)	No effect	No effect (OPEN disabled)
OPEN on PAUSE	Stops operation (3)	Stops operation (3)	Stops operation	No effect (if on part.opng., OPEN A disabled)	On release, closes after 5" (OPEN disabled)	On release, closes after 5" (OPEN disabled)
CLOSING	Re-opens the leaf immediately			No effect (saves OPEN)	see paragraph 5.2.	Locks and, on release, reverts to open
OPENING	Stops operation (3)	Stops operation (3)		Reverts to close	No effect (saves OPEN)	Locks and, on release, continues opening
LOCKED	Closes the leaf (3)		No effect (OPEN disabled)	No effect	No effect	No effect (OPEN disabled)

Tab. 3/g

PULSES						
Logic "B"	OPEN-A (opening)	OPEN-B (closing)	STOP	OPENING SAFETY DEVICES	CLOSING SAFETY DEVICES	OP/CL SAFETY DEVICE
GATE STATUS						
CLOSED	Opens the leaf	No effect	No effect (OPEN B disabled)	No effect (OPEN A disabled)	No effect	No effect (OPEN A disabled)
OPEN	No effect	Closes the leaf	Stops operation	No effect (saves OPEN A)	No effect (OPEN B disabled)	No effect (OPEN B disabled)
CLOSING	Reverts to open	No effect	Stops operation	Stops operation (OPEN-A disabled)	Stops operation (OPEN-B disabled)	Stops operation (OPEN-A/B disabled)
OPENING	No effect	No effect	No effect (OPEN A/B disabled)	No effect (OPEN-A disabled)	No effect (OPEN B disabled)	No effect (OPEN A/B disabled)
LOCKED	Opens the leaf	Closes the leaf				

Tab. 3/h

CONTROLS ALWAYS HELD DOWN						
Logic "C"	OPEN-A (opening)	OPEN-B (closing)	STOP	OPENING SAFETY DEVICES	CLOSING SAFETY DEVICES	OP/CL SAFETY DEVICE
GATE STATUS						
CLOSED	Opens the leaf	No effect (OPEN-A disabled)	No effect (OPEN A/B disabled)	No effect (OPEN A disabled)	No effect	No effect (OPEN A disabled)
OPEN	No effect (OPEN-B disabled)	Closes the leaf	Stops operation	No effect (OPEN A disabled)	No effect (OPEN B disabled)	No effect (OPEN B disabled)
CLOSING	Stops operation	/	Stops operation	No effect	Stops operation (OPEN-B disabled)	Stops operation (OPEN-A/B disabled)
OPENING	/	Stops operation		Stops operation (OPEN-A disabled)	No effect	

- (1) If maintained, it prolongs the pause until disabled by the command (timer function)
 - (2) If a new pulse occurs within 2 seconds after reversing, it immediately stops operation.
 - (3) During the partial opening cycle, an OPEN A pulse causes total opening.
- NB.: Effects on other active pulse inputs in brackets.

LIMITED WARRANTY

FAAC International, Inc. ("Seller") warrants the first Purchaser of the product to be free from defects in material and workmanship for a specific period as defined by the Warranty disclosure on the website www.faacusa.com. The Warranty Period commences from the date of invoice.

Control Boards, Accessories or Spare Parts factory installed or sold with any of the products above carry the same warranty period as the product they are sold with, excluding batteries that carry a maximum 2 year warranty.

Products repaired under warranty carry the remainder of the original warranty period. For products repaired outside of warranty, the Seller warrants that all parts used for the repair will be free from defects in materials and workmanship for a period of ninety (90) days.

Defective products must be returned to Seller, freight prepaid by Purchaser, within the warranty period. A Return Material Authorization Number (RMA) must be obtained before product is returned. Items returned will be repaired or replaced, at Seller's option, upon an examination which discloses to the satisfaction of the Seller that the item is defective. The Seller will return the warranted item freight prepaid.

This limited Warranty covers the product under the normal use and service for which it was intended, provided it has been properly installed and operated. Seller's obligations under this warranty shall be limited to the repair or exchange of any part. This warranty shall not apply to products or parts thereof which have been repaired or altered, without Seller's written consent, outside of Seller's workshop or altered in any way so as, in the judgment of Seller, to affect adversely the stability or reliability of the product(s) or has been subject of misuse, negligence, or accident, or has not been operated in accordance with the product's instructions or has been operated under conditions more severe than, or otherwise exceeding, those set forth in the specifications for such product(s).

When the warranty service involves the exchange of an operator or part, the item the Seller replaces becomes its property and the replacement becomes Purchaser's property. The Purchaser represents that all removed items are genuine and unaltered. The replacement may not be new but will be in good working order and at least functionally equivalent to the item replaced. The replacement assumes the warranty service status of the replaced item.

The products are not warranted to meet the specific requirements, if any, of safety codes of any particular state, municipality, or other jurisdiction, and the Seller doesn't assume any risk or liability whatsoever resulting from the use thereof, whether used singly or in combination with other machines or apparatus.

The Seller does not assume nor authorizes any person to assume for them any other liability in connection with the sale or use of the products of beyond that extended herein.

The warranty hereinabove set forth shall not be deemed to cover maintenance parts, including, but not limited to hydraulic oil, motor brushes, or the like. No agreement to replace or repair shall constitute an admission by the Seller of any legal responsibility to effect such replacement to make such repair, or otherwise.

All products sold by the Seller are subject to design and/or appearance modifications, which are production standards at the time of shipment. The Seller may, but shall not be required to, modify or update products shipped prior to a current production standard.

THIS WARRANTY IS EXPRESSLY IN LIEU OF ALL OTHER WARRANTIES EXPRESSED OR IMPLIED INCLUDING THE WARRANTIES OF MERCHANTABILITY AND FITNESS FOR USE. THIS WARRANTY SHALL NOT APPLY TO PRODUCTS OR ANY PART THEREOF WHICH HAVE BEEN SUBJECT TO ACCIDENT, NEGLIGENCE, ALTERATION, ABUSE, OR MISUSE OR IF DAMAGE WAS DUE TO IMPROPER INSTALLATION OR USE OF IMPROPER POWER SOURCE, OR IF DAMAGE WAS CAUSED BY FIRE, FLOOD, LIGHTNING, ELECTRICAL POWER SURGE, EXPLOSION, WIND STORM, HAIL, AIRCRAFT OR VEHICLES, VANDALISM, RIOT OR CIVIL COMMOTION, OR ACTS OF GOD.

The Seller shall not be liable for any loss or damage whatsoever resulting, directly or indirectly, from the use or loss of use of the product(s). Without limiting the foregoing, this exclusion from liability embraces a Purchaser's expenses for downtime or for making up downtime, lost profit, damages for which the Purchaser may be liable to other persons, damage to property, and injury to or death of any persons.

This limited warranty extends only to wholesale customers who buy directly through the Seller's normal distribution channels. The Seller does not warrant its products to end consumers. Consumers must inquire from their selling dealer as to the nature and extent of that dealer's warranty, if any.

THE LIMITED WARRANTY OFFERED HEREIN IS THE SOLE AND EXCLUSIVE REMEDY AVAILABLE TO THE PURCHASER. CORRECTION OF DEFECTS, IN THE MANNER AND FOR THE PERIOD OF TIME DESCRIBED HEREIN, SHALL CONSTITUTE THE COMPLETE FULFILLMENT OF ALL LIABILITIES OF SELLER TO THE PURCHASER WITH RESPECT TO THE COVERED PRODUCT, AND SHALL CONSTITUTE FULL SATISFACTION OF ALL CLAIMS, WHETHER BASED ON CONTRACT, NEGLIGENCE, STRICT LIABILITY OR OTHERWISE. IN NO EVENT SHALL SELLER BE LIABLE FOR ANY LOSS OF PROFITS OR ANY INDIRECT, CONSEQUENTIAL, INCIDENTAL, SPECIAL OR PUNITIVE DAMAGES ARISING OUT OF SELLER'S BREACH OF THIS LIMITED WARRANTY, OR ARISING OUT OF THE CUSTOMER'S INABILITY TO USE THE COVERED PRODUCT, EVEN IF SELLER HAS BEEN ADVISED OF THE POSSIBILITY OF SUCH DAMAGES.

Some states do not allow the exclusion or limitation of incidental or consequential damages, so the above limitation may not apply to a particular Purchaser. This Limited Warranty gives the Purchaser specific legal rights. The Purchaser may also have other rights, which vary from state to state.

